

MGMIHS

WASTE MANAGEMENT MOUs & AGREEMENTS

&

WASTE RECYCLING PLANTS

(STP/ETP/WATER TREATMENT PLANT)

MGMIHS

**BIOMEDICAL WASTE
MOUs & AGREEMENTS**



Towards sustainable growth



Mumbai Waste Management Limited

SERVICE CERTIFICATE

MIS M G M Hospital - kamothe

is a registered members of

CBMW-TSDF at MIDC, Talaja

for safe & secure disposal of

Bio Medical Waste.

Registration no.: MWML - BMW PAN-1069

This Certificate is valid upto

31st Dec'2022 For 810 Beds.

Somnath Malgar
Project Head

Certificate No.: MWML-BMW-2021-2022/04234

MAHARASHTRA POLLUTION CONTROL BOARD

Tel: 24010437/24020781/24014701
Fax: 24024068 /24023515
Website: <http://mpcb.gov.in>
E-mail : cac-cell@mpcb.gov.in



Kalpataru Point, 2nd - 4th Floor,
Opp. Cine Planet Cinema,
Near Sion Circle, Sion (E)
Mumbai - 400 022

Red/LSI

Consent No: Format 1.0/BO/UAN No.62150 /CAC - 1906001274

Date: 25/6/2019.

To,
M/s MGM's Medical College and Hospital,
N-6, CIDCO Aurangabad-432003.

Sub : Combined Consent to operate and BMW Authorization under RED Category to Health Care Establishment (HCE's).

Ref : 1. Consent granted by the Board vide no.BO/CAC-Cell/CCA-9767 Dated 12.08.2016 valid up to 31.12.2018.
2. Your application for combine consent to operate and BMW Authorization dated 07.12.2018.
3. The minutes of Consent Appraisal Committee meeting dated 02.05.2019.

Combined Consent to Establish and BMW Authorization.

under Section 26 of the Water (Prevention & Control of Pollution) Act, 1974 & under Section 21 of the Air (Prevention & Control of Pollution) Act, 1981, Authorization under Rule 5 of the Hazardous Wastes (M, H & T M) Rules 2016 and Biomedical Waste Management Rules 2016 and amendment in Rules 2018 is considered and the consent is hereby granted subject to following terms and conditions and as detailed in the schedule I, II, III, IV & V annexed to this order:

1. The conditional combined consent to operate and BMW authorization is granted for period up to 31.12.2023.
2. The capital investment of the HCE is Rs.154.96 Crs.(As per C. A. Certificate submitted)
3. The Consent is valid for the Activity of -

Sr. No.	Activity	
1	Hospital	
a)	Beds	700 Nos.
b)	Total Plot Area	20,000 Sq. Mtrs
c)	Total Built up Area	16,787 Sq. Mtrs

4. Conditions under Water (P&CP), 1974 Act for discharge of effluent:

Sr. no.	Description	Permitted quantity of discharge (CMD)	Standards to be achieved	Disposal
1	Trade effluent	22.0	As per Schedule -I	The treated trade effluent shall be recycled for secondary purpose such as toilet flushing, air conditioning, cooling tower make up, firefighting etc. and remaining shall be used for gardening /connected to the sewerage system provided by local body.
2	Domestic effluent	540.0	As per Schedule -I	

5. Conditions under Air (P& CP) Act, 1981 for air emissions:

Sr. no.	Description of stack / source	Number of Stack	Standards to be achieved
1	D.G.Set [600 KVA]	1	As per Schedule-II
2	D.G.Set [600 KVA]	1	
3	D.G.Set [750 KVA]	1	

6. Conditions under Hazardous Wastes (Management, Handling Transboundary and Other Waste) Rule 2016 for treatment and disposal of Hazardous Waste:

Sr. No.	Type of Waste	Quantity	UOM	Treatment	Disposal
1	35.3 Chemical sludge from ETP	As actual	Nil	--	At CHWTSDF

7. Non-Hazardous Solid Wastes:

Sr. No.	Type of Waste	Quantity	UOM	Treatment	Disposal
1	Wet Garbage	As actual	Kg/Day	OWC	Manure
2	Dry Garbage	As actual	Kg/Day	---	Recycle or hand over to local body
3	STP Sludge	As actual	Kg/Day	---	Manure

8. The authorization is granted for generation and disposal of Bio-Medical Waste (BMW) to CBMWTSDF in waste categories and quantities listed here in below:

Sr. No.	Category	Type of Waste	Quantity not to exceed (Kg/M)	Segregation Color coding	Treatment & Disposal
1	Yellow	a) Human Anatomical waste	90.0	Yellow colored non-chlorinated plastic bags	No onsite treatment of BMW is permitted. The above-mentioned Bio medical Waste shall be sent to Common BMW Treatment & Disposal facility authorized by MPCB.
		b) Animal Anatomical Waste	---		
		c) Soiled Waste	250.0		
		d) Expired or Discarded Medicines	2.0		
		e) Chemical Waste	---		
		f) Chemical Liquid Waste	---	Separate collection system leading to effluent treatment system	
		g) Discarded linen, mattresses, beddings contaminated with blood or body fluid.	9.0	Yellow colored non-chlorinated plastic bags or suitable packing material	
		h) Microbiology Biotechnology and other clinical laboratory waste	5.0	Autoclave safe plastic bags or containers	

2	Red	Contaminated waste (Recyclable)	300	Red colored non chlorinated plastic bags or containers	No onsite treatment of BMW is permitted. The above-mentioned Bio medical Waste shall be sent to Common BMW Treatment & Disposal facility authorized by MPCB.
3	White (Translucent)	Waste sharps including Metals	135	Puncture proof, Leak proof, tamper proof container	
4	Blue	a) Glassware b) Metallic body implants	31 ---	Puncture proof & leak proof boxes or containers with blue colored marking.	

9. If Built up area exceeds more than 20,000 sq. meters and if hospital is commissioned after 14.09.2006, the project proponent shall comply EIA Notification 2006 as Amended.

10. This consent is issued subject to conditions mentioned below,

- a. The "authorized Person" shall comply with provisions of the Environment (Protection) Act, 1986, and the Rules made there under.
- b. Any unauthorized change in equipment or working conditions as mentioned in the application by the person authorized shall constitute a breach of this Authorization.
- c. If the built-up area exceeds more than 20,000 sq. Mtrs. and if the hospital is commissioned after 14.09.2006, the project proponent shall comply EIA Notification 14.09.2006 by obtaining Environment Clearance.
- d. You shall submit details of Management and Handling of outdated, discarded, unused **Cytotoxic drugs** generated in the Cancer centers, research and health care in the format prescribed by CPCB which is available on www.cpcb.nic.in along with Annual Report to MPCB with a copy to CPCB before 31st January every year.
- e. You shall manage the **Mercury Waste** in the HCE in environmentally sound manner (including storage, spilled collection, transportation and disposal) as per CPCB guidelines published on CPCB website www.cpcb.nic.in dated: 07.09.2010 as detailed in document entitled "Environmentally Sound Management of Mercury Waste in Health Care Facilities".
- f. You shall ensure phase out of chlorinated plastic bags, gloves and blood bags by HCEs within two years;
- g. You shall establish Bar code system within one year

- h. You shall ensure that the liquid waste is treated and disposed by all the occupier or operator of a CBWTF in accordance with the Water Act, 1974;
- i. You shall maintain day to day basis and display the monthly record Including Annual report on its website within two years from the date of Notification.
- j. You shall submit separate Bank Guarantees towards compliance of condition mentioned at Annexure – IV to Regional Office, within 30 days.
- k. You shall submit compliance of Bank Guarantee conditions every six months to Regional Officer, for verification purpose.
- l. You shall submit application for renewal of Combined Consent and Biomedical Waste authorization before 120 days along with appropriate fees.
11. This Board reserves the right to review, amend, suspend, revoke etc. this consent and the same shall be binding on the industry.
12. This consent should not be construed as exemption from obtaining necessary NOC/permission from any other Government agencies.
13. Project Proponent shall not take effective steps towards establishment prior to obtaining Environmental Clearance As per EIA Notification 2006 and amendment thereto. As per para 2 of EIA Notification dated 14.09.2006, the effective steps include starting of any construction work or preparation of land by the project management. However as clarified by the MOEF & CC vide office memorandum no.J-1103/41/2006-IA,II (I), Dated 19.08.2010, fencing of the site to protect it from getting encroached and construction of temporary shed (S) for the guard(S) & acquisition of land may not be treated as an effective steps.

For and on behalf of the
Maharashtra Pollution Control Board

(E. Ravendiran, IAS)
Member Secretary

Received Consent fee of –

Sr. No.	Amount (Rs.)	D.R. No.	Date	Bank
1	15,49,623	TXN 1812001366	12.12.2018	E- Payment
2	75,000/-	TXN 1812002590	24.12.2018	E- Payment
3	1,00,000/-	TXN 1901000998	09.01.2019	E- Payment
4	1,24,817/-	TXN 19060000847	11.06.2019	E- Payment

Copy to:

1. Regional Officer – MPCB, Aurangabad and Sub –Regional Officer – Aurangabad -1, MPCB – They are directed to ensure the compliance of the CCA conditions.
2. Chief Accounts Officer, MPCB, Mumbai- for information.
3. CAC/CC desk - for record & website updation purposes.

Schedule-I

1) Terms & Conditions for compliance of Water Pollution Control

1) A] As per your application you have provided Effluent treatment plant (ETP) of capacity 30 CMD for the treatment of trade effluent generated from the hospital activity.

B] The applicant shall operate the effluent treatment plant (ETP) to treat the trade effluent so as to achieve the following standards prescribed by the Board or under EP Act, 1986 and Rules made there under from time to time, whichever is stringent.

Sr. No.	Parameters	Discharge Standards applicable
		Limiting Concentration in mg/l, except for pH
01	pH	6.5-9.0
02	Total Suspended Solids	100
03	Oil & Grease	10
04	BOD (3 days 27°C)	30
05	COD	250
06	Detergent	2.0
07	Bio-Assay test	90 % survival of fish after 96 hours in 100 % effluent

C] The treated effluent shall be recycled for secondary purpose such as toilet flushing, air conditioning, cooling tower make up, firefighting etc. and remaining shall be used for gardening /connected to the sewerage system provided by local body. In no case, effluent shall find its way to any water body directly / indirectly at any time. Project proponent shall provide flow meter to ensure 60% recycling of treated sewage and shall maintain the records with data logging system.

2) A] As per your application you have provided sewage treatment plant (STP) of design capacity of 600 CMD for treatment of domestic sewage generated from the hospital and thereafter the treated effluent shall be discharged followed by Chlorination and the treated effluent shall be disposal to Municipal Sewer / Land application after achieving standard prescribed below:

B] The applicant shall operate the sewage treatment plant (STP) to treat the domestic effluent so as to achieve the following standards prescribed by the Board or under EP Act, 1986 and Rules made there under from time to time, whichever is stringent.

Sr. No.	Parameters	Discharge Standards applicable
		Limiting Concentration in mg/l, except for pH
01	pH	6.5-9.0
02	Total Suspended Solids	50
03	Oil & Grease	10
04	BOD (3 days 27°C)	30
05	COD	100
06	Bio-Assay test	90 % survival of fish after 96 hours in 100 % effluent

C] The treated effluent shall be recycled for secondary purpose such as toilet flushing, air conditioning, cooling tower make up, firefighting etc. and remaining shall be connected to the sewerage system provided by local body. In no case, effluent shall find its way to any water body directly / indirectly at any time. Project proponent shall provide flow meter to ensure 60% recycling of treated sewage and shall maintain the records with data logging system.



- 3) The Board reserves its rights to review plans, specifications or other data relating to plant setup for the treatment of waste water & the system for the disposal of effluent or in connection with the grant of any consent conditions. The Applicant shall obtain prior consent of the Board to take steps for expansion / modify or establish any modification to treatment and disposal system or an extension or addition thereto.
- 4) You shall ensure replacement of pollution control system or its parts after expiry of its expected life as defined by manufacturer so as to ensure the compliance of standards and safety of the operation thereof.
- 5) You shall provide Specific Water Pollution control system as per the conditions of EP Act, 1986 and rule made there under from time to time.

Water Consumption details:

Sr. No.	Purpose for water consumed	Water Consumption quantity CMD
1.	Industrial Cooling and boiler feed etc.,	---
2.	Domestic purpose	670.0
3.	Processing whereby water gets polluted & pollutants are easily biodegradable	27.0
4.	Processing whereby water gets polluted & pollutants are not easily biodegradable and are toxic	--
5	Other such as agriculture, gardening, etc.	--

Schedule-II

Terms & conditions for compliance of Air Pollution Control

1. As per your application, you have proposed / provided the Air pollution control (APC) system and also proposed to erect/erected following stack (s) to observe the following fuel pattern-

Sr. No.	Stack Attached to	Height in meter	Type of Fuel	Fuel Qty	SO ₂ In Kg/Day
1	D.G.Set [600 KVA]	4.5	HSD	130 Kg/hrs	62.4
2	D.G.Set [600 KVA]	4.5	HSD	130 Kg/hrs	62.4
3	D.G.Set [750 KVA]	4.5	HSD	132 Kg/hrs	63.36

2. The applicant shall provide stack height of mtrs operate and maintain above mentioned air pollution control system, so as to achieve the level of pollutants to the following standards:

Particulate matter	Not to exceed	150 mg/Nm ³
--------------------	---------------	------------------------

3. The Applicant shall obtain necessary prior permission for providing additional control equipment with necessary specifications and operation thereof or alteration or replacement/alteration well before its life come to an end or erection of new pollution control equipment.
4. The Board reserves its rights to vary all or any of the condition in the consent, if due to any technological improvement or otherwise such variation (including the change of any control equipment, other in whole or in part is necessary).



5. Conditions for D.G. Set

- a. Noise from the D.G. Set should be controlled by providing an acoustic enclosure or by treating the room acoustically.
- b. Industry should provide acoustic enclosure for control of noise. The acoustic enclosure/ acoustic treatment of the room should be designed for minimum 25 dB (A) insertion loss or for meeting the ambient noise standards, whichever is on higher side. A suitable exhaust muffler with insertion loss of 25 dB (A) shall also be provided. The measurement of insertion loss will be done at different points at 0.5 meters from acoustic enclosure/room and then average.
- c. Industry should make efforts to bring down noise level due to DG set, outside industrial premises, within ambient noise requirements by proper siting and control measures.
- d. Installation of DG Set must be strictly in compliance with recommendations of DG Set manufacturer.
- e. A proper routine and preventive maintenance procedure for DG set should be set and followed in consultation with the DG manufacturer which would help to prevent noise levels of DG set from deteriorating with use.
- f. D.G. Set shall be operated only in case of power failure.
- g. The applicant should not cause any nuisance in the surrounding area due to operation of D.G. Set.
- h. The applicant shall comply with the notification of MoEF dated 17.05.2002 regarding noise limit for generator sets run with diesel.

Schedule-IV: Bank Guarantees

Statement of conditions to be complied and Bank Guarantee imposed to ensure timely compliance to be observed by

Sr. No.	Activity / Condition to be Complied	Compliance Timeline (Months)	Bank Guarantee Amount
I (A)	Operation and Maintenance		
1	To Segregate and Handle BMW as per Rule	Continuous	Rs. 1,00,000/-
2	To provide STP adequate capacity within 3 months and Towards Operation and Maintenance of STP/ETP to achieve prescribed discharge standards	Continuous	Rs. 1,00,000/-
I (B)	Records		
1	To Maintain records of BMW and submission of Annual Report in Form -II before 31 st January	Continuous	Rs. 25,000/-
2	To maintain records of BMW material delivered to CBMWTSDF	Continuous	Rs. 25,000/-
II	Performance		
1	To provide BMW separate storage facility as per guidelines of CPCB	Continuous	Rs. 75,000/-

Note: You shall submit the B.G. valid for additional 4 month period after the validity of your granted CCA.

Schedule-V
General Conditions

The following general conditions shall apply as per the type of the industry

- 1) You shall provide facility for collection of environmental samples and samples of trade and sewage effluents, air emissions and hazardous waste to the Board staff at the terminal or designated points and shall pay to the Board for the services rendered in this behalf.
- 2) You should monitor effluent quality, stack emissions, noise and ambient air quality quarterly.
- 3) You shall provide ports in the chimney/(s) and facilities such as ladder, platform etc. for monitoring the air emissions and the same shall be open for inspection to/and for use of the Board's Staff. The chimney(s) vents attached to various sources of emission shall be designated by numbers such as S-1, S-2, etc. and these shall be painted/ displayed to facilitate identification.
- 4) Whenever due to any accident or other unforeseen act or even, such emissions occur or is apprehended to occur in excess of standards laid down, such information shall be forthwith Reported to Board, concerned Police Station, office of Directorate of Health Services, Department of Explosives, Inspectorate of Factories and Local Body. In case of failure of pollution control equipments, the production process connected to it shall be stopped.
- 5) You shall provide an alternate electric power source sufficient to operate all pollution control facilities installed to maintain compliance with the terms and conditions of the consent. In the absence, the applicant shall stop, reduce or otherwise, control production to abide by terms and conditions of this consent.
- 6) You shall submit, the Environmental Statement Report for the financial year ending 31st March in the prescribed Form-V as per the provisions of rule 14 of the Environment (Protection) (Second Amendment) Rules, 1992 to Regional Office, , the 30th day of September every year.
- 7) You shall recycle/reprocess/reuse/recover Hazardous Waste as per the provision contain in the HW (MH&TM) Rules 2008, which can be recycled /processed /reused /recovered and only waste which has to be incinerated shall go to incineration and waste which can be used for land filling and cannot be recycled/reprocessed etc should go for that purpose, in order to reduce load on incineration and landfill site/environment.
- 8) You shall comply with the Hazardous Waste (M, H & TM) Rules, 2008 and submit the Annual Returns to RO- as per Rule 5(6) & 22(2) of Hazardous Waste (M, H & TM) Rules, 2008 for the preceding year April to March in Form-IV by 30th June of every year.
- 9) An inspection book shall be opened and made available to the Board's officers during their visit to the HCE.
- 10) You shall strictly comply with the Water (P&CP) Act, 1974, Air (P&CP) Act, 1981 and Environmental Protection Act, 1986 and industry specific standard under EP Rules 1986 which are available on MPCB website (www.mpcb.gov.in).
- 11) You shall constitute an Environmental cell with qualified staff/personnel/agency to see the day to day compliance of consent & authorization condition towards Environment Protection.
- 12) Separate drainage system shall be provided for collection of trade and sewage effluents. Terminal manholes shall be provided at the end of the collection system with arrangement for measuring the flow. No effluent shall be admitted in the pipes/sewers downstream of the terminal manholes. No effluent shall find its way other than in designed and provided collection system.

महाराष्ट्र MAHARASHTRA

4 MAY 2011

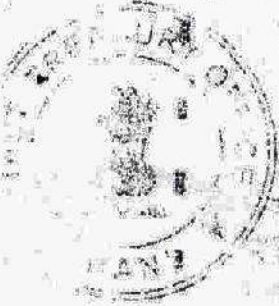

मुद्रांक पत्रगृह लिपिक
संभार कार्यालय, ठाणे
4-5-11

विद्रीचे ठिकाण: अंधार सर्व्हिसेस

राज्य नं.6, जयन्ता मार्केट, सी.3, नेरुल,

मदी मुद्रांक-400708 मो.: 8221178271

अ. नं. 2161 व 50

नाम Mumbai Waste Management Ltd.

वस्तु Development Yadan.

Geren

AGREEMENT मंगळूर मारुती कारडे
मुद्रांक दिक्का ला. नं. 23/99

Agreement made on the 13th day of June, 2011 between

1. Mumbai Waste Management Limited (a Ramky Group Company) situated at Plot No. P-32, MFD, Talaja, Talaja Pandal, District - Raigad, Maharashtra, and having its Corporate office at 6-3-1089/G/10 & 11, Geethabai Rajbhavan Road, Somajiguda, Hyderabad-500082 (herein after called "MWML") of the FIRST PART, represented by Operating Officer Mr. Dinkar N. Adhav (which expression include their successors and assigns, unless such inclusion is inconsistent with the context or meaning thereof)

and

2. Mahatma Gandhi Mission Hospital - Kamothe having their Health Care Establishments at Plot No. E & F, Kamothe, Navi Mumbai - 410209, (Herein after called "GENERATOR") of the SECOND PART, represented by Superintendent Dr. V. J. Mahadik (which expression include their successors and assigns, unless such inclusion is inconsistent with the context or meaning thereof).

MWML has setup a common facility at Talaja for Collection, Transport and Disposal of the Bio-Medical Waste (called "BMW"), generated by the Health Care Establishments (HCEs - Hospitals, Nursing Homes, Clinics, Diagnostic & R&D centers.)

MGMIHS

E-WASTE MOUs & AGREEMENTS



महाराष्ट्र MAHARASHTRA

© 2018 ©

TY 728342

प्रधान मुद्रांक कार्यालय, मुंबई
प.मु.वि.क. ८००००९६
30 OCT 2018
सक्षम अधिकारी

श्रीमती. पी. एस. तळवणे

AGREEMENT FOR E-WASTE MANAGEMENT SERVICES

This Agreement for E-waste Management Services (hereinafter referred to as "AGREEMENT") is made at this 18 day of December in Two thousand and 18. at Mumbai

BY AND BETWEEN

Envirocare Recycling Private Limited, registered under Registrar of Companies, CIN No.: U37200MH2009PTC198219, and having its registered office at D-504, Firdous Park, 80, S.V.Road, Jogeshwari West, Mumbai 400102. Envirocare Recycling Private Limited, (herein after referred as "Envirocare Recycling Private" which expression shall unless contrary to the context or meaning thereof, mean and include its successors and permitted assigns) of ONE PART

AND

The MGM Institute of Health Sciences, Navi Mumbai (Deemed to be University under section 3 of the UGC Act, 1956), having its office at MGM Educational Campus, Plot No. 1&2, Sector -01, Kamothe, Navi Mumbai- 410209 (herein after referred as "MGMIHS" which expression shall unless contrary to the context or meaning thereof, mean and include its successors and permitted assigns) of SECOND PART

Envirocare Recycling Private Limited and MGMIHS are individually called as "Party" and collectively as "Parties".

For ENVIROCARE RECYCLING PVT. LTD.



DIRECTOR



1 2 NOV 2018

459

/Annexure-I

फक्त प्रतिज्ञापनासाठी / Only For Affidavit

१) मुद्रांक विक्री नोंदवही अणु. क्रमांक/दिनांक
(Serial No./Date)

२) मुद्रांक विकत घेणाऱ्याचे नांव व रहिवाशांचा पत्ता व सही
(Stamp Purchaser's Name/Place
residence & Signature)

३) परवानाधारक मुद्रांक विक्रेत्याची सही व परवाना क्रमांक

तोसेच मुद्रांक विक्रीचे ठिकाण/पत्ता

परवाना क्रमांक ८००००१६

मुद्रांक विक्रीचे ठिकाण/पत्ता:

बॉम्बे नगर असोसिएशन, फारुखर विल्डींग, २री मळा, लॉयर चेंबर,

बॉम्बे मेट्रोपोलिटन मॅजिस्ट्रेट कोर्ट, व्. के. मार्ग, बांद्रे (पूर्व), गुं. ४०० ०५१.

शासकीय कार्यालयासमोर/ न्यायालयासमोर प्रतिज्ञापन सादर

करणेसाठी मुद्रांक कागदाची आवश्यकता नाही.

१) शसन आदेश दि. ०१/०८/२००४ नुसार) ज्या कागदावर मुद्रांक खरेदी

मुद्रांक खरेदी केला त्याची त्याच प्रकारचा मुद्रांक खरेदी

ल्यापासून ६ महिन्यात कागद बंधनकारक आहे

ENVIROCARE RECYCLING PVT. LTD.
D-504, Firdos Park,
80, S. V. Road, Near Sabri Masjid
Jogeshwari (E), Mumbai-400 102.

P. G. P.

गोपाळ नारिकेल

- (A) **Envirocare Recycling Private Limited** is engaged in the business of providing services or operating a facility relating to collection, transportation, dismantling, recycling of electrical & electronic waste, refurbishing & remarketing of used electronic equipment, data destruction, lamp recycling and other related services like implementation of Extended Producers Responsibility (EPR), partnering for Corporate Social Responsibility (CSR), Skill Development, Setting up Collection Network etc. Envirocare Recycling Private Limited is authorized by the Maharashtra Pollution Control Board and registered with the Central Pollution Control Board.
- (B) **MGM Institute of Health Sciences, Navi Mumbai** is a Deemed to be University under section 3 of the UGC Act, 1956, which runs and administers Educational Institutes in Navi Mumbai and Aurangabad.
- (C) **MGMIHS**, & its institutes in their normal day to day functioning generate in the normal course various kinds of electrical & electronic wastes which it (hereinafter referred to as "e-waste", more particularly specified in Annexure – I) intends to hand over the said e-waste to **Envirocare Recycling Private Limited** for safe & secure disposal. **Envirocare Recycling Private Limited** undertakes to dispose the same as per the Rules of E-waste Management and as per the guidelines of the Central Pollution Control Board or any other authorities and availing related services.

Interpretation:

1. In this Agreement, unless the context otherwise requires.
2. References to persons shall include, as relevant, individuals, bodies of corporate (wherever incorporated), unincorporated associations, trusts, partnerships and proprietorships;
3. References to one gender includes all genders;
4. Any reference to any enactment, statutory provision, rule or regulation is a reference to it as it may have been, or may from time to time be, amended, modified, consolidated or re-enacted;
5. Words in the singular shall include the plural and vice versa;
6. The terms "hereof", "herein", "hereto" and derivative or similar words refer to this entire Agreement or specified sections of this Agreement, as the case may be;
7. Each capitalized term used herein has the meaning assigned to such term herein;

In view of the aforesaid including the intended representations and warranties, as stated in Clause 8 of this Agreement, MGMIHS is desirous of availing the services offered by **Envirocare Recycling Private Limited** as per the details contained in Annexure - II hereto, at Navi Mumbai and Aurangabad campus. The parties hereto have agreed to the following terms and conditions:

1. Services

Envirocare Recycling Private Limited shall provide to MGMIHS, the service(s) as set forth in Annexure – II to this Agreement (hereinafter referred to as the "Services"). Annexure – II is subject to written amendments or modifications at the instance of MGMIHS from time to time.

All services including as amended or modified from time to time, are, and will be, an integral part of this Agreement, unless there is express and specific indication to the contrary.

Similarly, all schedules to this Agreement, as amended or modified from time to time, are and will be an integral part of this Agreement, unless there is express and specific indication to the contrary.

2. MGMIHS shall send written intimation in electronic or physical format to **Envirocare Recycling Private Limited** of the quantitative details & services required and addresses of the locations from where e-waste is to be collected & services to be provided for. **Envirocare Recycling Private Limited** agrees that it shall pay the negotiated & agreed amount (which would be the best in the market at that moment) to MGMIHS for the e-waste which is generated.

3. Pursuant to the intimation and with prior written permission, **Envirocare Recycling Private Limited** may carry out inspection of the above e-waste at the location(s)/premises of MGMIHS.

4. **Envirocare Recycling Private Limited** shall send the details of the methodology for the disposal of e-waste and services as per the above intimation for the approval of MGMIHS. On receipt of the approval of MGMIHS, **Envirocare Recycling Private Limited** shall proceed with the destruction of data, collection, transportation, dismantling, recycling of electrical & electronic waste etc.



PRIVILEGED AND CONFIDENTIAL

For ENVIROCARE RECYCLING PVT. LTD.

DIRECTOR



2

5. Representations and Warranties:

5.1 The services shall be executed, and provided to MGMIHS, in a professional manner;

5.2 **Envirocare Recycling Private Limited** shall at all times under this Agreement shall ensure that the requirements of MGMIHS are catered to and the obligations and duties of **Envirocare Recycling Private Limited** under this Agreement are complied with in the true spirit;

5.3 **Envirocare Recycling Private Limited** represents and warrants that it complies with all applicable laws, rules and regulations and amendments/modifications made thereto. **Envirocare Recycling Private Limited** represents and warrants that it has, and shall at all relevant times have all the requisite and valid licenses and permissions from all regulatory and statutory authorities, for providing the services including the Services under this Agreement and that the same shall be kept renewed and in force and effect at all times.

5.4 **Envirocare Recycling Private Limited** may deploy its own resources or authorized representatives or avail of the services of the third party to do the needful as per the terms of the invoice(s). The said authorized representative or third party shall be bound by the terms of this agreement.

5.5 The parties agree that under this agreement no Hard Disk will be given. In case any Hard Disk is inadvertently handed over or **Envirocare Recycling Private Limited** comes in possession of any hard disk owned by or belonging to MGMIHS, then in that event **Envirocare Recycling Private Limited** undertakes to return the hard disk to MGMIHS. **Envirocare Recycling Private Limited** undertakes that it shall not compromise with the data stored on the data devices as received along with e-waste

6. Agreement Terms

Duration

6.1 The duration of this Agreement shall be for an initial period of 5 years from the date of the execution of this Agreement, unless it is terminated with mutual consent of the parties in this Agreement. This Agreement shall automatically stand terminated on the expiry of the initial period and may be renewed by the parties with mutual consent. The parties agree that MGMIHS is free to negotiate and enter into agreement with other entities providing similar services during the existence of this agreement.

Breach of Agreement and Termination

6.2 In the event of breach of any of the terms of this Agreement, the party who has observed such breach is entitled to give notice to the other party with an intention to rectify the breach within 30 days of the receipt of the notice, if corrective action is not taken by the party committing breach then the party giving notice shall be entitled to terminate this Agreement with immediate effect.

6.3 This Agreement may stand terminated with immediate effect, in case either party goes into liquidation, voluntary or compulsory.

6.4 This Agreement may be terminated with mutual consent, if either party feels that the continuance of the agreement is prejudicial to the business of the affected party.

Force Majeure: -

6.5 In case of force majeure reasons this Agreement may stand terminated.

Disputes/Arbitration: -

7. In case of any dispute, both the parties must first resolve the dispute internally, failing which they shall refer the matter to a third party which shall be decided mutually by both parties. The third party shall be considered as an Arbitrator and the dispute shall be governed by the rules of Arbitration and Conciliation Act, 1996.

Indemnity:

8. **Envirocare Recycling Private Limited** indemnify and agrees to keep MGMIHS fully indemnified for breach of services agreed to be provided for by **Envirocare Recycling Private Limited**.

Waiver: -



For **ENVIROCARE RECYCLING PVT. LTD.**

DIRECTOR



9. The request for waiver / amendment of any of the terms, conditions, or provisions of this Agreement requested by any of the parties of this Agreement must be sent to other party in writing and shall only be valid if signed by both the parties.

10. Notices:

Any notice or other formal communication to be given under and for the purposes of this Agreement shall be in writing and signed by or on behalf of the party giving it. It shall be (a) sent in digital form to the e-mail set out below; or (b) delivered by hand or sent by registered post acknowledgement due, to the relevant address set out below.

MGM Institute of Health Sciences Address: MGM Campus, Sector 1, Kamothe, Navi Mumbai-410209 Contact Person: Dr. Rajesh B. Goel E-mail ID: registrar@gmail.com Contact Number: 022-27432471/ 27432994	Envirocare Recycling Private Limited Address: D-504, Firdous Park, 80, S.V.Road, Jogeshwari (W), Mumbai 400102 Contact Person: Hafiz Ansari E-mail ID: hafizransari@envirocareindia.co.in Contact Number: 022-26772217/982009450
---	---

Relationship

11. The relationship established under this Agreement is that of independent parties and nothing in this Agreement shall be construed:

11.1 to give either party the power to direct or control the daily activities of the other party;

11.2 to constitute the parties as employer and employee, principal and agent, partners, joint ventures, co-owners or otherwise as participants in a joint undertaking; or

11.3 to allow either party to create or assume any obligation on behalf of the other party for any purpose whatsoever.

Confidentiality: -

12. **Envirocare Recycling Private Limited** acknowledges and agrees that throughout the term of this Agreement and even thereafter **Envirocare Recycling Private Limited** ensures to maintain the confidentiality of such information, received during the course of rendering services by its employees and authorized representatives and limit disclosure of confidential information to its employees / representatives who need to know such confidential information for the performance of their duties under this Agreement. **Envirocare Recycling Private Limited** also agrees that it shall not use or exploit such confidential information for its own benefit or the benefit of the others.

13. Governing Law and Jurisdiction:

This Agreement, the construction and enforcement of its terms and the interpretation of the rights and duties of the parties hereto shall be subject to and governed by the laws of India.

14. The Agreement is executed in duplicate and one copy will be retained by MGMIHS and the other by **Envirocare Recycling Private Limited**, each of which shall be deemed as an original, both of which shall together constitute one and the same instrument.

15. This Agreement constitutes the entire agreement between the parties with respect to the subject matter hereof and supersedes all prior agreements between the parties, whether written or oral, relating to the same subject matter. No modification, amendment or supplement to this Agreement shall be effective for any purpose unless in writing, signed by each party.

16. Entirety of the Agreement

This Agreement together with all Appendices, Exhibits, Schedules, Attachments and Addenda attached hereto from time to time constitute the entire agreement between the parties and supersedes all and any previous agreements, promises, representations, understandings and negotiations, whether written or oral, between the parties with respect to the subject matter hereof.



For **ENVIROCARE RECYCLING PVT. LTD.**

DIRECTOR



PRIVILEGED AND CONFIDENTIAL

4



IN WITNESS WHEREOF the parties have put their respective signatures hereunder the day and year first hereinabove written.

SIGNED SEALED AND DELIVERED

By the within named "MGM Institute of Health Sciences, Navi Mumbai"
through its Registrar

Witness:



- 1. Rajesh Mathijani 
- 2. M. Mukesh S. Deoze

)
)
)
)
)
)
)

 Dr. Rajesh B. Goel
 Registrar
 MGM Institute of Health Sciences
 (Deemed University u/s 3 of UGC Act, 1986)
 Navi Mumbai- 410 209

 01/12/2018

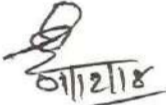
SIGNED SEALED AND DELIVERED

By the within named "Envirocare Recycling Private Limited"
through its Director

Witness:

- 1. Rajesh Mathijani 
- 2. Shahna waj' Alam 

)
)
)
)
)
)
)
 For ENVIROCARE RECYCLING PVT. LTD.
 DIRECTOR

ANNEXURE - I

ANNEXURE -1

Sr. No.	Item Type
1	Desktops including CPU, Monitor & I/O accessories
2	Laptops
3	Mainframes
4	Servers & Storage devices
5	Network Equipment
6	Printers, Copiers & Cartridges
7	Telephone & Cellular Equipment
8	UPS
9	Air Conditioners
10	Home & Kitchen appliances
11	Medical Equipment
12	Other Electronic & Electrical Equipment & components



For ENVIROCARE RECYCLING PVT. L^{TD}

DIRECTOR



ANNEXURE – II

Brief of Services offered by Envirocare Recycling Private Limited:

E-waste Management – Envirocare Recycling Private Limited boasts of best in class set-up for end to end e-waste management services. The facility registered with CPCB & MPCB and is certified for R2, ISO 9001, ISO 14001, OHSAS 18001 & ISO 27001. The facility comprises of world class technology for processing e-waste.

Data Destruction – Envirocare Recycling Private Limited provides data destruction in all formats viz. Destruction, Degaussing and Deletion using software. These services are rendered using tools that meets global standards. **Envirocare Recycling Private Limited** has also developed unique data destruction on Wheels facility. This award winning technology enables us to destroy devices at client's premises thereby helping them comply with their data security policy.

IT Assets Disposition – Envirocare Recycling Private Limited provides ITAD services in line with the global best practices. The service is intended to recover value from used assets by refurbishing the assets. Clients have to specifically opt for this service. The service includes, data sanitization followed by asset cleansing, and testing whereby passed assets are refurbished and failed assets are sent for recycling.

Corporate Social Responsibility – Envirocare Recycling Private Limited is persistent industry leader and pioneer towards ensuring that the corporates dispose their e-waste in the most scientific, transparent and environment-friendly manner. Additionally, **Envirocare Recycling Private Limited** provides options for CSR initiatives.

Extended Producer's Responsibility Implementation– The E-waste (Management) Rules, 2016 has effected target based EPR. **Envirocare Recycling Private Limited** assists Producers of Electronic and Electrical Equipment to effectively implement their EPR and also helps achieving the target compliance.

Skill Development – Envirocare Recycling Private Limited Enviro Education envisaged the need of skill development way before the same has now been suggested in the E-waste Management Rules, 2016



For ENVIROCARE RECYCLING PVT. LTD.

DIRECTOR



AGREEMENT FOR PURCHASE OF E-WASTE

This Agreement for Purchase of E-Waste (Contract) is entered into on 11 day of October of the year Two thousand sixteen by and amongst-

green e-bin electronic waste solution having its Registered office at MGM Institute of Management, MGM Campus, N-6, CIDCO, Aurangabad, Maharashtra 431003 and Project Office at B-18 MIDC Chikalthana Aurangabad 431006 (herein after referred as "GEBEWS" which expression shall unless contrary to the context or meaning thereof, mean and include its successors and permitted assigns) represented by Mr. Ashish Gadekar.

WHEREAS;

- A. GEBEWS is operating a facility for the collection, transportation, dismantling, refurbishing and disposal of e-waste at B-18 MIDC Chikalthana Aurangabad 431006 by Maharashtra Pollution Control Board.
- B. The Generator in compliance of the E-Waste Management & Handling Rules, 2011, desires to avail the services of GEBEWS for disposal of their segregated E-Waste, more fully detailed hereinafter under this Agreement.
- C. The Generator has approached GEBEWS and desires to appoint GEBEWS for the purpose of collection and disposal of its segregated E-Waste and the same has been accepted by GEBEWS in accordance with the terms of this Agreement.

NOW THIS AGREEMENT witnesses as follows;

I. DEFINITIONS AND INTERPRETATION

1. Electronic Waste (E-Waste) - The term E-Waste will refer to the below mentioned electrical and electronic waste for the purpose of this Agreement which includes;
 - a) Computers & Peripherals (CPU, Keyboard, Mouse& Monitor)
 - b) Laptops
 - c) Servers
 - d) PCBs
 - e) Mobiles or Communication devices



B-18 MIDC Chikalthana,
Opposite CTR Mfg,
Aurangabad 431006

ewaste@greenebin.co.in
Call: 99210 40501

green e-bin

electronic waste solution

MPCB Consent: BO/MPCB/RO (HQ)/Aurangabad/CO/B-1806000425
MPCB Authorization: MPCB/RO(HQ)/HSMD/Author/16/EW-344
GST: 27AHWPG0991P1ZE

- f) Mother Boards (Computers & Laptops)
- g) Security Devices
- h) Telecom Equipment
- i) Printers & Scanners
- j) Military Electronic
- k) Control Systems
- l) Data cables & wires
- m) Batteries
- n) CD/DVD

Dr. Rajesh B. Goel
Registrar
MGM INSTITUTE OF HEALTH SCIENCES
(DEEMED UNIVERSITY u/s 3 of UGC Act, 1956)
NAVI MUMBAI- 410 209

2. In this Agreement, unless the subject or context otherwise requires:
- a. Reference to the singular number shall include references to the plural number and vice-versa;
 - b. References to a "person" shall include references to natural persons, partnership firms, companies, bodies corporate and associations, whether incorporated or not or any other organization or entity including any governmental or political sub-division, ministry, department or agency thereof;
 - c. References to recitals, clauses and schedules are to recitals, clauses and schedules to this Agreement;
 - d. Any reference herein to a statutory provision shall include such provision, as is in force for the time being and as from time to time, amended or re-enacted in so far as such amendment or re-enactment is capable of applying to any transactions covered by this Agreement.
 - e. Clause headings used herein are only for ease of reference and shall not affect the interpretation of this Agreement.
3. The Schedules & Annexure shall form an integral part of this Agreement.
4. All capitalized terms used in this agreement shall have the meaning specifically defined in this Agreement shall, unless inconsistent with the context under this Agreement.

II. SCOPE OF THE AGREEMENT

1. GEBEWS shall collect, transport, and dispose the E-Waste collected from the premises of the Generator. It shall be the responsibility of GEBEWS to demagnetize the hard disks before disposing them off in accordance with the terms of the contract. If the hard disks come along with the CPU the activity would be taken care by GEBEWS at free of cost.

B-18 MIDC Chikalthana,
Opposite CTR Mfg,
Aurangabad 431006



green e-bin

electronic waste solution

MPCB Consent: BO/MPCB/RO (HQ)/Aurangabad/CO/B-1806000425
MPCB Authorization: MPCB/RO(HQ)/HSMD/Author/16/EW-344
GST: 27AHWPG0991P1ZE

However, in case of an exclusive consignment of hard disks for demagnetization by the Generator. It shall be chargeable in accordance with the terms of the contract.

2. The Generator shall appoint a dedicated representative who shall be responsible for operational, delivery and day to day management of the Service and act as the principal point of contact under this Agreement. Any notice seeking clarification served on such representative shall be deemed to have been served on the Party concerned. The representative of the Generator shall sign Form 13 under the compliance of the E-Waste Management & Handling Rules, 2011, and such other required documents for acknowledging the E-Waste being handed over to GEBEWS.
3. The Generator shall segregate the E-Waste at one designated place within the premises from where the representatives of GEBEWS shall collect the E-Waste. All the segregated E-Waste shall be stored in the appropriate bins and/or container as prescribed under the applicable law and GEBEWS shall not be liable for any damage caused due to in appropriate storage of E-Waste at the premises by the Generator.
4. Upon intimation from the Generator, GEBEWS shall within 15 days there from, arrange for collection of E-Waste as per the applicable provisions. The Generator shall issue delivery challan before collection of the E-Waste from the designated place by GEBEWS.
5. The E-Waste collected shall be weighed by the Parties at the nearest weighment center available as identified by the Parties. The weighment of the E-Waste shall be done in the presence of the representatives of both the Parties and both the Parties shall acknowledge such weighment slip generated. In case of any discrepancy in the weighment as per delivery challan and the weighment slip, the details as per weighment slip shall be considered for payment by GEBEWS.
6. The Generator liability shall cease once the E-Waste has been collected by GEBEWS from its premises except for any non-disclosure of any material information known to the Generator with regard to E-Waste from GEBEWS during the handover of such E- Waste. It is specifically agreed and understood that compliances of applicable law during transportation and disposal of E-Waste shall be exclusive responsibility of the GEBEWS.
7. GEBEWS shall, issue a safe destruction certificate as prescribed under applicable laws within fifteen (15) days from receipt of such request.

III. PAYMENTS

1. GEBEWS shall pay according to the agreed rates exclusive of GST ...per each kilogram for payment of E-Waste collected shall be as per the weighment slip submitted and accepted by GEBEWS.

B-18 MIDC Chikalhana,
Opposite CTR Mfg,
Aurangabad 431006



2. The payment shall be made by GEBEWS within thirty (30) days of the collection of E-Waste in the form of a electronic transfer/ cheque. GEBEWS may withhold any payment in case of any dispute regarding the weightment of E-Waste and any such withholding of payment shall under this clause shall not be considered as a material breach of this Agreement.

IV. TERM AND TERMINATION

1. This Agreement shall be in force for a period of 5 years from the date of signing of this Agreement. Upon completion of the term, the Agreement may be renewed at the option of both the Parties in writing on mutually agreed terms and conditions.
2. The Agreement may be terminated by either party without assigning any reason, by giving fifteen (15) days prior written notice to the other Party.

V. COMPLIANCE WITH LAWS

1. GEBEWS represents and warrants to the Generator that it has all necessary statutory permissions, consents, approvals and licenses to carry out business of collection, transportation, storage, management and disposal of E-Waste and it shall maintain all such permissions, consents, approvals and licenses during the term of this Agreement.
2. GEBEWS further agrees that:
 - i. It shall exercise all safety precaution and best management practices, required by law, in providing service under this Agreement;
 - ii. It shall notify the Generator immediately if any permit, licenses, certificate, consent approval or identification number required for the performance of its service under this Agreement has been revoked, modified, expired, suspended or not been renewed;
 - iii. GEBEWS shall comply with all applicable laws, rules and regulations and shall indemnify and hold the Generator harmless in this regard;

VI. ENVIRONMENTAL AND SAFETY AUDITS

1. GEBEWS agrees and acknowledges that the Generator or its authorized agent shall have the right to perform environmental and safety audit at any site at which GEBEWS is conducting E-Waste management services for the purpose of verifying environmental and safety procedures followed by GEBEWS.
2. GEBEWS shall also cooperate with the Generator, in the event any statutory agency

B-18 MIDC Chikalthana,
Opposite CTR Mfg,
Aurangabad 431006



conducts any audit or inspection to check the Generator's procurement, disposal and management of E-Waste by providing necessary reports, documents, certificates and other relevant information upon giving reasonable notice in advance of any such audits.

VII. LIMITATION OF LIABILITY

Notwithstanding anything to the contrary mentioned in this Agreement, in no event shall Parties be liable for any special, indirect, incidental or consequential damage, including but not limited to loss of sales, business or data, lost profits or loss of use or other equipment or goodwill, incurred by any Party or any direct or indirect loss or damage.

VIII. DISPUTE RESOLUTION

1. This Agreement shall be governed and construed in accordance with the laws of India.
2. Any dispute or breach arising out of or in relation to this Agreement shall be referred to arbitration to be conducted by a sole arbitrator mutually appointed by the parties herein, in accordance with the Arbitration and Conciliation Act, 1996. The venue of arbitration shall be Hyderabad and the proceedings shall be conducted in English. The decision of the arbitration shall be final and binding on both the Parties. No Party shall make public the award of the arbitration without the prior written consent of the other Party. The Party in default shall bear the cost of arbitration.
3. Subject to the arbitration provisions herein, courts of competent jurisdiction in Hyderabad shall have the exclusive jurisdiction on the matters arising out of or in connection with this Agreement. No Party shall be restrained from approaching the court for seeking interim relief under this Agreement.

IX. Execution of this Agreement shall be deemed to be

1. A confirmation by both the Parties that no benefit, either in cash or kind has been provided by either Party to the other Party or to any officer or employee, or any relative/ associate of any officer or employee of either Party or of any of their associate institutions/companies in order to enter into this Agreement;
2. An undertaking by both the Parties not to provide any benefit, either in cash or kind to any officer/employee/relative/associate of any officer or employee of either Party as reward or consideration either for entering into this Agreement or other matter relating to this Agreement.

X. MISCELLANEOUS



B-18 MIDC Chikalthana,
Opposite CTR Mfg,
Aurangabad 431006

ewaste@greenebin.co.in
Call: 99210 40501

1. Force Majeure: Neither party shall be liable for any delay or failure to perform its obligations here under, if such delay or failure is due to reasons beyond the control of the concerned party due to any Force Majeure event which shall include but not limited to, strikes, riots, wars, fires, epidemics, quarantine restrictions, unusually severe weather, earth quakes, explosions, acts of God or state or any public enemy or acts mandated by applicable laws, regulation or order of any Governmental body. The Party affected by such Force Majeure event shall immediately notify the other Party who shall have the right to terminate the Agreement with immediate effect upon giving a written notice if such Force Majeure event continues for more than sixty (60) days.
2. Confidentiality: The existence and all terms and conditions of this Agreement are confidential to the Parties, and shall not be disclosed to any third party without the other party's prior written consent, save and except to their respective officers, employees or as required by law on a need to know basis. The confidentiality obligation under this Agreement shall exist during the term of this Agreement and for a period of three (3) years from the expiry of this Agreement.
3. Notice: Any notice or other communication under or in connection with this agreement shall be in writing in the English language and shall be delivered personally or delivered to the party due to receive the notice or communication at its address set out below or such other address as either party may specify by notice in writing to other from time to time.
4. Amendment & Modification: Amendments and modifications to this Agreement shall be valid only if made in writing and signed by the Parties.
5. No Representation: Nothing in this Agreement shall authorize any Party to engage in transactions in the name of the other Party or in any activities, which may create a liability on such other Party.
6. No Assignment: Parties shall not assign or transfer this Agreement or any Order or any parts of its rights and obligations hereunder to any person or corporation without the prior written consent of the other Party.
7. No Waiver: No failure to exercise, nor any delay in exercising, on the part of either Party, any right or remedy hereunder shall operate as a waiver thereof, nor shall any single or partial exercise of any right or remedy prevent any further or other exercise thereof or the exercise of any other right or remedy.
8. Headings: The headings of the Clauses of this Agreement are for convenience only and shall have no effect in the interpretation of this Agreement.
9. Entire Agreement: This Agreement and the Order(s) constitute the entire agreement between the Parties.
10. Duplicate Agreements: This Agreement has been signed in two counterparts, each of which shall be deemed as an original but both of which together shall constitute one and

B-18 MIDC Chikalthana,
Opposite CTR Mfg,
Aurangabad 431006



ewaste@greenebin.co.in
Call: 99210 40501

the same instrument.

IN WITNESS WHEREOF, this Agreement has been signed by the duly authorized representatives of each Party hereto.

For **green e-bin electronic waste solution**
B-18 MIDC Chikalthana Aurangabad 431006
Maharashtra. Contact: 9921040501

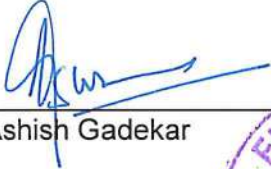

Mr. Ashish Gadekar

Owner of GEBEWS

Date: 11-10-2016



For **MGM Medical College and hospital, (MGMMC) N-6 Cidco , Aurangabad -431003.**
Maharashtra. Contact: 0240-6601100



Dr. Rajendra Bohra

Dean of MGMMCHA

Date: 11 Oct 2016



B-18 MIDC Chikalthana,
Opposite CTR Mfg,
Aurangabad 431006

ewaste@greenebin.co.in
Call: 99210 40501

green e-bin

electronic waste solution

MPCB Consent: BO/MPCB/RO (HQ)/Aurangabad/CO/B-1806000425
MPCB Authorization: MPCB/RO(HQ)/HSMD/Author/16/EW-344
GST: 27AHWPG0991P1ZE

Standard Operating Procedure for E-Waste (IT Scrap) Disposal

Issue No. 01

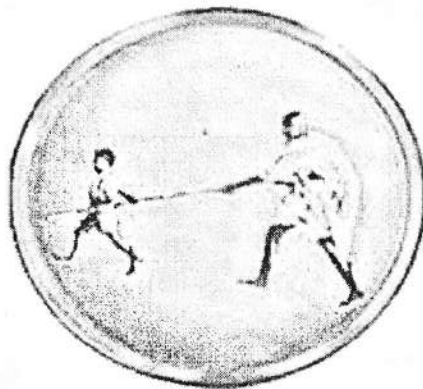

MGM Institute of Health Sciences

MGM Campus, Sector 1, Kamothe, Navi Mumbai-410209

www.mgmuhs.com

Document Details	
Issue Number:	01
Release date:	
MS Word file name:	MGMIHSewaste_disposalSOP.docx
Document Prepared By:	IT Manager, MGMIHS

Revision History		
Revision Number	Release Date	Brief Description or Notes

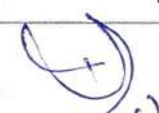
Approvals		
Department	Name & Designation	Sign with Date
University	Dr. Shashank Dalvi Vice Chancellor	 4/6/19
University	Dr. Rajesh B Goel Registrar	 4/6/19.

Document Summary
This document defines a Standard Operating Procedure for E Waste Disposal being followed in MGMIHS and its constituent colleges. It also mentions the applicable policies, standards and documents.

Document Release Note
This document is released for use in MGM Institute of Health Sciences and its Constituent Units.

1. Purpose

This Document briefs the disposal process of non-functioning of IT assets (E-Waste), and guidelines to be followed at MGMIHS and its constituent units.

2. Scope

This process will be deployed and sustained at MGM Institute of Health Sciences and its constituent units in both of its campuses located in Navi Mumbai and Aurangabad.

3. Procedure

- All the users from other departments raises the request to IT department for troubleshooting the problematic IT assets such as desktops, laptops, servers, printers etc.
- Based on the Service Request, the Hardware Technicians from IT Department identifies that whether respective asset is Working or Not.
- If the respective asset is found to be working or repairable, then it is kept for maintenance purposes
- In case the IT asset is more than 7 years and not repairable, then the System Administrator verifies in details and submits the report to respective authorities after labelling it as Scrap. The same is reported to IT manager also
- IT Manager consolidates the IT scraps (e-waste) of all departments and submits the consolidated list to the Medical Director, MGM for e-waste disposal.
- Based on the approval from the Medical Director, MGM; IT Manager raises the purchase request for IT scrap disposal with Stores Department.
- The Stores Department calls the quotations from the Authorized vendors for IT scrap disposal and receive the proposals from Vendors.
- The Stores department negotiates with the vendors and shortlists the appropriate vendor for IT scrap disposal in presence of Finance Officer.
- The IT Manager then handovers the IT Scrap (e-waste) to the shortlisted vendor and sends the IT scrap to vendor's e-waste hub.

4. Responsibilities

IT Manager is responsible for consolidating the IT Scrap and coordinate for disposal of IT scrap to shortlisted vendor as per the Stores Department.

5. Flow chart

Process Flow chart

E- Waste Management – Process

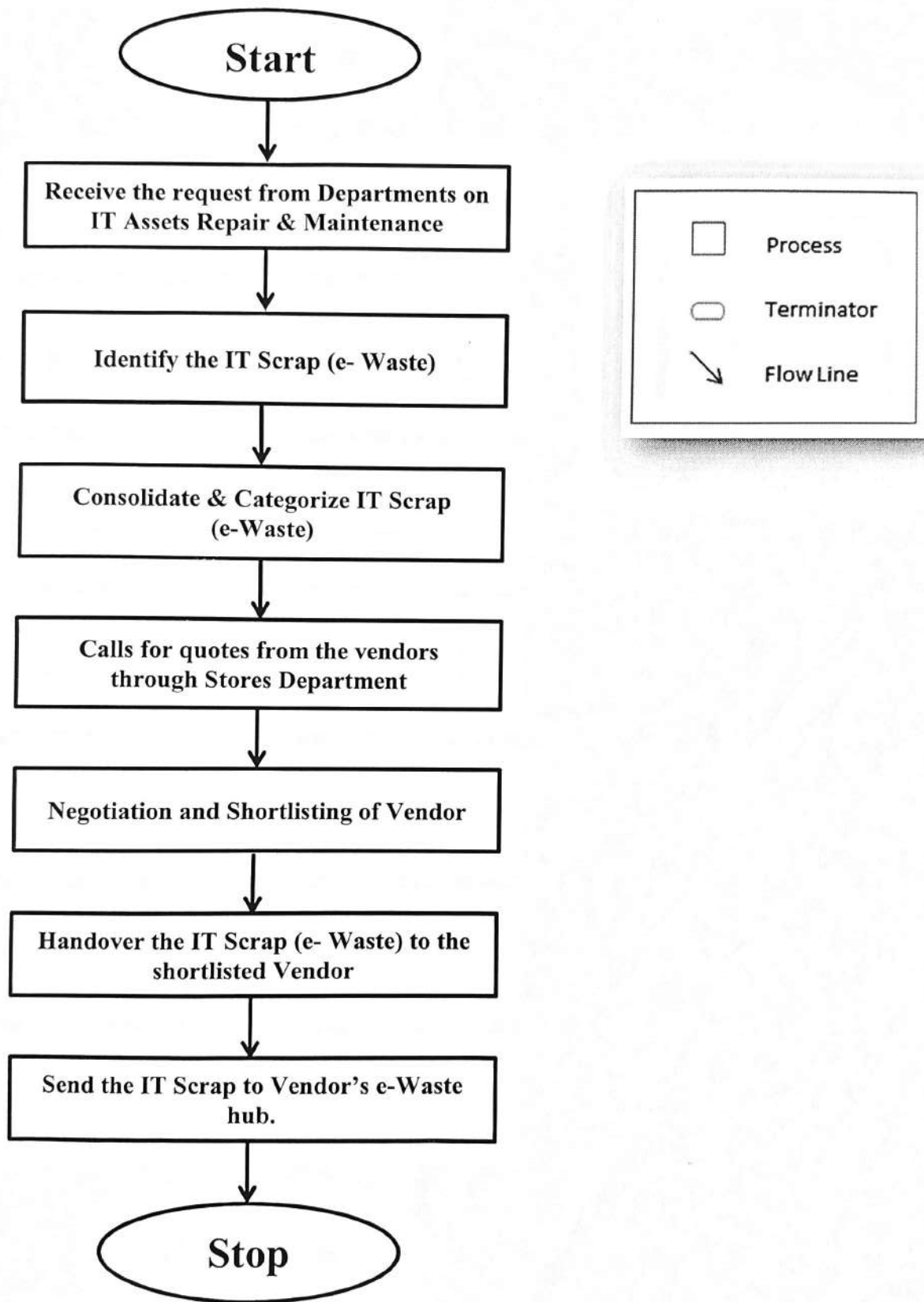

Certificate of e-waste disposal

This is to certify that the e-waste received from

MAHATMA GANDHI MISSION, AURANGABAD

during the period from 1998 to 2016 has been disposed off in an environmentally

friendly manner, vide certificate No. ECO-GE3/2016/02 dated 24-AUG-2017

We appreciate your efforts in contributing to a greener environment.

For green e-bin

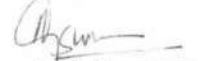
Auth. Signatory



green e-bin

electronic waste solutions

MPCB/RO/HQ/HSMD/Aurho/16/EW-344
RO/MPCB/RO (HQ)/Aurangabad,CO/3-161200759
B-1H MIDC Chikalthana, Aurangabad 431006

MGMIHS

RADIATION SAFETY CERTIFICATES



Case File Number: MH-20778-RF-XR-016

Issuance Date: 27/10/2015

Document Number: 15-LOEE-67404

Expiry Date: 27/10/2020

REGISTRATION FOR OPERATION OF MEDICAL DIAGNOSTIC X-RAY EQUIPMENT

In exercise of powers conferred under Section 16 of the Atomic Energy Act, 1962 read in conjunction with Rule (3) of the Atomic Energy (Radiation Protection) Rules {AE(RP)R}, 2004, the Atomic Energy Regulatory Board (AERB) hereby issues **Registration** in favour of Dr. PRAKASH DOKE to operate the following medical diagnostic x-ray equipment located at MAHATMA GANDHI MISSION HOSPITAL, KAMOTHE, PLOT NO. 1 AND 2, SECTOR 1, KAMOTHE OPPOSITE MC DONALD NAVI MUMBAI, MAHARASHTRA-410209 for medical diagnostic purpose.

Type of Equipment	Manufacturer	Model	Equipment ID
Radiography (Fixed)	ALLENERS MEDICAL SYSTEMS LTD.	MARS 50	G-XR-40534

The **MEDICAL SUPERINTENDENT, MAHATMA GANDHI MISSION HOSPITAL, KAMOTHE, NAVI MUMBAI** and **DR. PRAKASH DOKE** are hereby identified as the Employer and licensee respectively, for the purpose of assigning the responsibilities specified in the Atomic Energy (Radiation Protection) Rules, 2004, in respect of radiation protection of workers, public and environment because of operation of the above equipment.

The Employer and Licensee are responsible for,

- I. Ensuring compliance with the relevant provisions of the
 - i. Atomic Energy Act, 1962
 - ii. Atomic Energy (Radiation Protection) Rules, 2004;
 - iii. AERB Safety Code (AERB/SC/Med-2), 2001, Amendment 2012, and the revisions thereof
 - iv. All applicable Safety Codes, Guides issued by AERB for the above practice and regulatory documents issued by AERB from time to time.
 - v. Directives issued by Competent Authority from time to time.
- II. Ensuring compliance with terms and conditions stated overleaf.

Note:

This Registration is issued ONLY from the RADIATION SAFETY VIEW POINT. All other clearances shall be obtained from concerned state/central/local authorities as applicable.

Dr. Avinash U. Sonawane
Head, RSD

DR. PRAKASH DOKE
MAHATMA GANDHI MISSION HOSPITAL, KAMOTHE
PLOT NO. 1 AND 2, SECTOR 1, KAMOTHE OPPOSITE MC DONALD
NAVI MUMBAI, MAHARASHTRA-410209

Copy to: MEDICAL SUPERINTENDENT, MAHATMA GANDHI MISSION HOSPITAL, KAMOTHE, NAVI MUMBAI

Note: This document is also available at www.aerb.gov.in/elora



परमाणु ऊर्जा नियामक परिषद्, नियामक भवन, अनुष्ठातिनगर, मुंबई 400094 (गुजरातराष्ट्र)
Atomic Energy Regulatory Board, Niyamak Bhavan, Anushaktinagar, Mumbai 400094 (Maharashtra)

वेबसाइट/Website: www.aerb.gov.in

दूरभाष/Tel: 91-22-2599 0656



An ISO 9001:2009
Organization

फैक्स/Fax: 91-22-2599 0650



Case File Number: MH-20778-RF-XR-021

Issue Date: 04/07/2016

Document Number: 16-LOP-117026

Expiry Date: 04/07/2021

REGISTRATION FOR OPERATION OF MEDICAL DIAGNOSTIC X-RAY EQUIPMENT

In exercise of powers conferred under Section 16 and 17 as applicable of Atomic Energy Act, 1962 read in conjunction with Rule (3) of the Atomic Energy (Radiation Protection) Rules {AE(RP)R}, 2004, the Atomic Energy Regulatory Board (AERB) hereby issues Registration in favour of DR. PRAKASH DOKE to operate the following diagnostic radiology equipment located at PLOT NO. 1 AND 2, SECTOR 1, KAMOTHE OPPOSITE MC DONALD NAVI MUMBAI, MAHARASHTRA-410209 for Medical Diagnosis purposes.

Type of Equipment	Manufacturer	Model	Equipment Id
Radiography (Fixed)	M/s. Allengers Medical Systems Limited , India	MARS-50+	G-XR-53017

The MEDICAL SUPERINTENDENT, MAHATMA GANDHI MISSION HOSPITAL, KAMOTHE, NAVI MUMBAI and DR. PRAKASH DOKE are hereby identified as the Employer and licensee respectively, for the purpose of assigning the responsibilities specified in the Atomic Energy (Radiation Protection) Rules, 2004, in respect of radiation protection of workers, public and environment because of operation of the above equipment.

The Employer and Licensee are responsible for,

- I. Ensuring compliance with the relevant provisions of the
 - i. Atomic Energy Act, 1962
 - ii. Atomic Energy (Radiation Protection) Rules, 2004;
 - iii. AERB Safety Code (AERB/SC/Med-2), 2001, Amendment 2012, and the revisions thereof
 - iv. All applicable Safety Codes, Guides issued by AERB for the above practice and regulatory documents issued by AERB from time to time.
 - v. Directives issued by Competent Authority from time to time.
- II. Ensuring compliance with terms and conditions stated overleaf.

Note:

This Registration is issued ONLY from the RADIATION SAFETY VIEW POINT. All other clearances shall be obtained from concerned state/central/local authorities as applicable.

Dr. Avinash U. Sonawane
Head, RSD

DR. PRAKASH DOKE, MEDICAL SUPERINTENDENT
MAHATMA GANDHI MISSION HOSPITAL, KAMOTHE
PLOT NO. 1 AND 2, SECTOR 1, KAMOTHE OPPOSITE MC DONALD
NAVI MUMBAI, MAHARASHTRA-410209

CC: MEDICAL SUPERINTENDENT, MAHATMA GANDHI MISSION HOSPITAL, KAMOTHE, NAVI MUMBAI

Note: This document is also available at www.aerb.gov.in/lor



परमाणु ऊर्जा नियामक परिषद्, नियामक भवन, अणुसक्तिनगर, मुंबई 400094 (महाराष्ट्र)
Atomic Energy Regulatory Board, Niyamak Bhavan, Anushaktinagar, Mumbai 400094 (Maharashtra)

वेबसाइट/Website: www.aerb.gov.in

दूरभाष/Tel: 91-22-2599 0656



फैक्स/Fax: 91-22-2599 0650



Case File Number: MH-20778-RF-XR-002

Issuance Date: 01/08/2017

Document Number: 15-RLXE-51007

Expiry Date: 01/08/2022

REGISTRATION FOR OPERATION OF MEDICAL DIAGNOSTIC X-RAY EQUIPMENT

In exercise of powers conferred under Section 16 and 17 as applicable of Atomic Energy Act, 1962 read in conjunction with Rule (3) of the Atomic Energy (Radiation Protection) Rules {AE(RP)R}, 2004, the Atomic Energy Regulatory Board (AERB) hereby issues **Registration** in favour of Dr. PRAKASH PRABHAKARRAO DOKE to operate the following medical diagnostic x-ray equipment located at MAHATMA GANDHI MISSION HOSPITAL, KAMOTHE, PLOT NO. 1 AND 2, SECTOR 1, KAMOTHE OPPOSITE MC DONALD NAVI MUMBAI, MAHARASHTRA-410209 for medical diagnostic purpose.

Type of Equipment	Manufacturer	Model	Equipment ID
Radiography (Fixed)	Aristho Medical Pvt Ltd.	Tridoros 6R	G-XR-12734

The **MEDICAL SUPERINTENDENT, MAHATMA GANDHI MISSION HOSPITAL, KAMOTHE, NAVI MUMBAI** and **DR. PRAKASH PRABHAKARRAO DOKE** are hereby identified as the Employer and licensee respectively, for the purpose of assigning the responsibilities specified in the Atomic Energy (Radiation Protection) Rules, 2004, in respect of radiation protection of workers, public and environment because of operation of the above equipment.

The Employer and Licensee are responsible for,

- I. Ensuring compliance with the relevant provisions of the
 - i. Atomic Energy Act, 1962
 - ii. Atomic Energy (Radiation Protection) Rules, 2004;
 - iii. AERB Safety Code (AERB/SC/Med-2), 2001, Amendment 2012, and the revisions thereof
 - iv. All applicable Safety Codes, Guides issued by AERB for the above practice and regulatory documents issued by AERB from time to time.
 - v. Directives issued by Competent Authority from time to time.
- II. Ensuring compliance with terms and conditions stated overleaf.

Note:

This Registration is issued ONLY from the RADIATION SAFETY VIEW POINT. All other clearances shall be obtained from concerned state/central/local authorities as applicable.

Dr. Avinash U. Sonawane
Head, RSD

DR. PRAKASH PRABHAKARRAO DOKE
MAHATMA GANDHI MISSION HOSPITAL, KAMOTHE
PLOT NO. 1 AND 2, SECTOR 1, KAMOTHE OPPOSITE MC DONALD
NAVI MUMBAI, MAHARASHTRA-410209

Copy to: MEDICAL SUPERINTENDENT, MAHATMA GANDHI MISSION HOSPITAL, KAMOTHE, NAVI MUMBAI

Note: This document is also available at www.aerb.gov.in/elora



परमाणु ऊर्जा नियामक परिषद्, नियामक भवन, अणुशक्तिनगर, मुंबई 400094 (महाराष्ट्र)
Atomic Energy Regulatory Board, Niyamak Bhavan, Anushaktinagar, Mumbai 400094 (Maharashtra)

वेबसाइट/Website: www.aerb.gov.in

दूरभाष/Tel: 91-22-2599 0656



An ISO 9001:2008
Organization

फैक्स/Fax: 91-22-2599 0650



अध्यक्ष
Chairman

Case File Number: MH-20778-RF-XL-028

Issue Date: 22/01/2018

Document Number: 18-LOP-248749

Expiry Date: 22/01/2023

LICENSE FOR OPERATION OF MEDICAL DIAGNOSTIC X-RAY EQUIPMENT

In exercise of powers conferred under Section 16 and 17 as applicable of Atomic Energy Act, 1962 read in conjunction with Rule (3) of the Atomic Energy (Radiation Protection) Rules {AE(RP)R}, 2004, the Atomic Energy Regulatory Board (AERB) hereby issues Licence in favour of Dr. PRAKASH PRABHAKARRAO DOKE to operate the following diagnostic radiology equipment located at PLOT NO. 1 AND 2, SECTOR 1, KAMOTHE OPPOSITE MC DONALD NAVI MUMBAI, MAHARASHTRA-410209 for Medical Diagnosis purposes.

Type of Equipment	Manufacturer	Model	Equipment Id
Computed Tomography	M/s. Toshiba Medical System Corporation	Activion 16	G-XL-80360

The MEDICAL SUPERINTENDENT, MAHATMA GANDHI MISSION HOSPITAL, KAMOTHE, NAVI MUMBAI and Dr. PRAKASH PRABHAKARRAO DOKE are hereby identified as the Employer and licensee respectively, for the purpose of assigning the responsibilities specified in the Atomic Energy (Radiation Protection) Rules, 2004, in respect of radiation protection of workers, public and environment because of operation of the above equipment.

The Employer and Licensee are responsible for;

- I. Ensuring compliance with the relevant provisions of the
 - i. Atomic Energy Act, 1962
 - ii. Atomic Energy (Radiation Protection) Rules, 2004;
 - iii. AERB Safety Code (AERB/SC/Med-2), 2001, Amendment 2012, and the revisions thereof
 - iv. All applicable Safety Codes, Guides issued by AERB for the above practice and regulatory documents issued by AERB from time to time.
 - v. Directives issued by Competent Authority from time to time.
- II. Ensuring compliance with terms and conditions stated overleaf.

Note:

This Licence is issued ONLY from the RADIATION SAFETY VIEW POINT. All other clearances shall be obtained from concerned state/central/local authorities as applicable.

(Competent Authority)

DR. PRAKASH PRABHAKARRAO DOKE
MAHATMA GANDHI MISSION HOSPITAL, KAMOTHE,
PLOT NO. 1 AND 2 SECTOR 1, KAMOTHE OPPOSITE MC DONALD,
NAVI MUMBAI-410209
MAHARASHTRA



परमाणु ऊर्जा नियामक परिषद्, नियामक भवन, अणुशक्तिनगर, मुंबई 400094 (महाराष्ट्र)
Atomic Energy Regulatory Board, Niyamak Bhavan, Anushaktinagar, Mumbai 400094 (Maharashtra)



An ISO 9001:2008
Organisation



Case File Number: MH-20778-RF-XR-003

Issuance Date: 01/08/2017

Document Number: 15-RLXE-51008

Expiry Date: 01/08/2022

REGISTRATION FOR OPERATION OF MEDICAL DIAGNOSTIC X-RAY EQUIPMENT

In exercise of powers conferred under Section 16 and 17 as applicable of Atomic Energy Act, 1962 read in conjunction with Rule (3) of the Atomic Energy (Radiation Protection) Rules {AE(RP)R}, 2004, the Atomic Energy Regulatory Board (AERB) hereby issues **Registration** in favour of **Dr. PRAKASH PRABHAKARRAO DOKE** to operate the following medical diagnostic x-ray equipment located at **MAHATMA GANDHI MISSION HOSPITAL, KAMOTHE, PLOT NO. 1 AND 2, SECTOR 1, KAMOTHE OPPOSITE MC DONALD NAVI MUMBAI, MAHARASHTRA-410209** for medical diagnostic purpose.

Type of Equipment	Manufacturer	Model	Equipment ID
Radiography (Fixed)	Aristho Medical Pvt. Ltd.	Heliophos D	G-XR-12736

The **MEDICAL SUPERINTENDENT, MAHATMA GANDHI MISSION HOSPITAL, KAMOTHE, NAVI MUMBAI** and **DR. PRAKASH PRABHAKARRAO DOKE** are hereby identified as the Employer and licensee respectively, for the purpose of assigning the responsibilities specified in the Atomic Energy (Radiation Protection) Rules, 2004, in respect of radiation protection of workers, public and environment because of operation of the above equipment.

The Employer and Licensee are responsible for;

- I. Ensuring compliance with the relevant provisions of the
 - i. Atomic Energy Act, 1962
 - ii. Atomic Energy (Radiation Protection) Rules, 2004;
 - iii. AERB Safety Code (AERB/SC/Med-2), 2001, Amendment 2012, and the revisions thereof
 - iv. All applicable Safety Codes, Guides issued by AERB for the above practice and regulatory documents issued by AERB from time to time.
 - v. Directives issued by Competent Authority from time to time.
- II. Ensuring compliance with terms and conditions stated overleaf.

Note:

This Registration is issued **ONLY** from the **RADIATION SAFETY VIEW POINT**. All other clearances shall be obtained from concerned state/central/local authorities as applicable.

Dr. Avinash U. Sonawane
Head, RSD

DR. PRAKASH PRABHAKARRAO DOKE
MAHATMA GANDHI MISSION HOSPITAL, KAMOTHE
PLOT NO. 1 AND 2, SECTOR 1, KAMOTHE OPPOSITE MC DONALD
NAVI MUMBAI, MAHARASHTRA-410209

Copy to: **MEDICAL SUPERINTENDENT, MAHATMA GANDHI MISSION HOSPITAL, KAMOTHE, NAVI MUMBAI**

Note: This document is also available at www.aerb.gov.in/elora



परमाणु ऊर्जा नियामक परिषद्, नियामक भवन, अणुशक्तिनगर, मुंबई 400094 (महाराष्ट्र)
Atomic Energy Regulatory Board, Niyamak Bhavan, Anushaktinagar, Mumbai 400094 (Maharashtra)

वेबसाइट/Website: www.aerb.gov.in

दूरभाष/Tel: 91-22-2599 0656



An ISO 9001:2008
Organization
फैक्स/Fax: 91-22-2599 0650



Case File Number: MH-20778-RF-XR-001

Issuance Date: 23/08/2017

Document Number: 15-RLXE-51005

Expiry Date: 23/08/2022

REGISTRATION FOR OPERATION OF MEDICAL DIAGNOSTIC X-RAY EQUIPMENT

In exercise of powers conferred under Section 16 and 17 as applicable of Atomic Energy Act, 1962 read in conjunction with Rule (3) of the Atomic Energy (Radiation Protection) Rules {AE(RP)R}, 2004, the Atomic Energy Regulatory Board (AERB) hereby issues **Registration** in favour of Dr. PRAKASH PRABHAKARRAO DOKE to operate the following medical diagnostic x-ray equipment located at MAHATMA GANDHI MISSION HOSPITAL, KAMOTHE, PLOT NO. 1 AND 2, SECTOR 1, KAMOTHE OPPOSITE MC DONALD NAVI MUMBAI, MAHARASHTRA-410209 for medical diagnostic purpose.

Type of Equipment	Manufacturer	Model	Equipment ID
Radiography (Fixed)	M/s. Siemens Limited	Pleophos D	G-XR-12724

The **MEDICAL SUPERINTENDENT, MAHATMA GANDHI MISSION HOSPITAL, KAMOTHE, NAVI MUMBAI** and **DR. PRAKASH PRABHAKARRAO DOKE** are hereby identified as the Employer and licensee respectively, for the purpose of assigning the responsibilities specified in the Atomic Energy (Radiation Protection) Rules, 2004, in respect of radiation protection of workers, public and environment because of operation of the above equipment.

The Employer and Licensee are responsible for,

- I. Ensuring compliance with the relevant provisions of the
 - i. Atomic Energy Act, 1962
 - ii. Atomic Energy (Radiation Protection) Rules, 2004;
 - iii. AERB Safety Code (AERB/SC/Med-2), 2001, Amendment 2012, and the revisions thereof
 - iv. All applicable Safety Codes, Guides issued by AERB for the above practice and regulatory documents issued by AERB from time to time.
 - v. Directives issued by Competent Authority from time to time.
- II. Ensuring compliance with terms and conditions stated overleaf.

Note:

This Registration is issued ONLY from the RADIATION SAFETY VIEW POINT. All other clearances shall be obtained from concerned state/central/local authorities as applicable.

Dr. Avinash U. Sonawane
Head, RSD

DR. PRAKASH PRABHAKARRAO DOKE
MAHATMA GANDHI MISSION HOSPITAL, KAMOTHE
PLOT NO. 1 AND 2, SECTOR 1, KAMOTHE OPPOSITE MC DONALD
NAVI MUMBAI, MAHARASHTRA-410209

Copy to: MEDICAL SUPERINTENDENT, MAHATMA GANDHI MISSION HOSPITAL, KAMOTHE, NAVI MUMBAI

Note: This document is also available at www.aerb.gov.in/elora



परमाणु ऊर्जा नियामक परिषद्, नियामक भवन, अणुशक्तिनगर, मुंबई 400094 (महाराष्ट्र)
Atomic Energy Regulatory Board, Niyamak Bhavan, Anushaktinagar, Mumbai 400094 (Maharashtra)

वेबसाइट/Website: www.aerb.gov.in

दूरभाष/Tel: 91-22-2599 0656



An ISO 9001:2008
Organisation

फैक्स/Fax: 91-22-2599 0650



अध्यक्ष
Chairman

Case File Number: MH-20778-RF-XL-022

Issuance Date: 20/07/2016

Document Number: 16-LOEE-120360

Expiry Date: 20/07/2021

LICENSE FOR OPERATION OF MEDICAL DIAGNOSTIC X-RAY EQUIPMENT

In exercise of powers conferred under Section 16 and 17 as applicable of Atomic Energy Act, 1962 read in conjunction with Rule (3) of the Atomic Energy (Radiation Protection) Rules (AE(RP)R), 2004, the Atomic Energy Regulatory Board (AERB) hereby issues Licence in favour of Dr. PRAKASH PRABHAKARRAO DOKE to operate the following medical diagnostic x-ray equipment located at MAHATMA GANDHI MISSION HOSPITAL, KAMOTHE, PLOT NO. 1 AND 2, SECTOR 1, KAMOTHE OPPOSITE MC DONALD NAVI MUMBAI, MAHARASHTRA-410209 for medical diagnostic purpose.

Type of Equipment	Manufacturer	Model	Equipment ID
Computed Tomography	M/s. Toshiba Medical System Corporation	Asteion KG	G-XL-53707

The MEDICAL SUPERINTENDENT, MAHATMA GANDHI MISSION HOSPITAL, KAMOTHE, NAVI MUMBAI and DR. PRAKASH PRABHAKARRAO DOKE are hereby identified as the Employer and licensee respectively, for the purpose of assigning the responsibilities specified in the Atomic Energy (Radiation Protection) Rules, 2004, in respect of radiation protection of workers, public and environment because of operation of the above equipment.

The Employer and Licensee are responsible for,

- I. Ensuring compliance with the relevant provisions of the
 - i. Atomic Energy Act, 1962
 - ii. Atomic Energy (Radiation Protection) Rules, 2004;
 - iii. AERB Safety Code (AERB/SC/Med-2), 2001, Amendment 2012, and the revisions thereof
 - iv. All applicable Safety Codes, Guides issued by AERB for the above practice and regulatory documents issued by AERB from time to time.
 - v. Directives issued by Competent Authority from time to time.
- II. Ensuring compliance with terms and conditions stated overleaf.

Note:

This Licence is issued ONLY from the RADIATION SAFETY VIEW POINT. All other clearances shall be obtained from concerned state/central/local authorities as applicable.

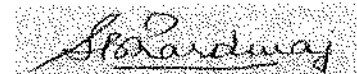

(Competent Authority)

DR. PRAKASH PRABHAKARRAO DOKE
MAHATMA GANDHI MISSION HOSPITAL, KAMOTHE
PLOT NO. 1 AND 2, SECTOR 1, KAMOTHE OPPOSITE MC DONALD
NAVI MUMBAI, MAHARASHTRA-410209



परमाणु ऊर्जा नियामक परिषद्, नियामक भवन, अणुशक्तिनगर, मुंबई 400094 (महाराष्ट्र)
Atomic Energy Regulatory Board, Niyamak Bhavan, Anushaktinagar, Mumbai 400094 (Maharashtra)



An ISO 9001:2008
Organisation



Case File Number: MH-20778-RF-XR-019

Issuance Date: 24/05/2016

Document Number: 16-LOEE-108091

Expiry Date: 24/05/2021

REGISTRATION FOR OPERATION OF MEDICAL DIAGNOSTIC X-RAY EQUIPMENT

In exercise of powers conferred under Section 16 and 17 as applicable of Atomic Energy Act, 1962 read in conjunction with Rule (3) of the Atomic Energy (Radiation Protection) Rules (AE(RP)R), 2004, the Atomic Energy Regulatory Board (AERB) hereby issues **Registration** in favour of Dr. PRAKASH PRABHAKARRAO DOKE to operate the following medical diagnostic x-ray equipment located at MAHATMA GANDHI MISSION HOSPITAL, KAMOTHE, PLOT NO. 1 AND 2, SECTOR 1, KAMOTHE OPPOSITE MC DONALD NAVI MUMBAI, MAHARASHTRA-410209 for medical diagnostic purpose.

Type of Equipment	Manufacturer	Model	Equipment ID
Radiography (Mobile)	M/s. Soma X-ray Company	Somex 100	G-XR-50231

The **MEDICAL SUPERINTENDENT, MAHATMA GANDHI MISSION HOSPITAL, KAMOTHE, NAVI MUMBAI** and **DR. PRAKASH PRABHAKARRAO DOKE** are hereby identified as the Employer and licensee respectively, for the purpose of assigning the responsibilities specified in the Atomic Energy (Radiation Protection) Rules, 2004, in respect of radiation protection of workers, public and environment because of operation of the above equipment.

The Employer and Licensee are responsible for;

- I. Ensuring compliance with the relevant provisions of the
 - i. Atomic Energy Act, 1962
 - ii. Atomic Energy (Radiation Protection) Rules, 2004;
 - iii. AERB Safety Code (AERB/SC/Med-2), 2001, Amendment 2012, and the revisions thereof
 - iv. All applicable Safety Codes, Guides issued by AERB for the above practice and regulatory documents issued by AERB from time to time.
 - v. Directives issued by Competent Authority from time to time.
- II. Ensuring compliance with terms and conditions stated overleaf.

Note:

This Registration is issued ONLY from the RADIATION SAFETY VIEW POINT. All other clearances shall be obtained from concerned state/central/local authorities as applicable.

Dr. Avinash U. Sonawane
Head, RSD

DR. PRAKASH PRABHAKARRAO DOKE
MAHATMA GANDHI MISSION HOSPITAL, KAMOTHE
PLOT NO. 1 AND 2, SECTOR 1, KAMOTHE OPPOSITE MC DONALD
NAVI MUMBAI, MAHARASHTRA-410209

Copy to: MEDICAL SUPERINTENDENT, MAHATMA GANDHI MISSION HOSPITAL, KAMOTHE, NAVI MUMBAI

Note: This document is also available at www.aerb.gov.in/elora



परमाणु ऊर्जा नियामक परिषद्, नियामक भवन, अणुशांतिनगर, मुंबई 400094 (महाराष्ट्र)
Atomic Energy Regulatory Board, Niyamak Bhavan, Anushaktinagar, Mumbai 400094 (Maharashtra)



An ISO 9001:2008
Organization



Case File Number: MH-20778-RF-XR-024

Issue Date: 22/03/2017

Document Number: 17-LOP-173694

Expiry Date: 22/03/2022

REGISTRATION FOR OPERATION OF MEDICAL DIAGNOSTIC X-RAY EQUIPMENT

In exercise of powers conferred under Section 16 and 17 as applicable of Atomic Energy Act, 1962 read in conjunction with Rule (3) of the Atomic Energy (Radiation Protection) Rules (AE(RP)R), 2004, the Atomic Energy Regulatory Board (AERB) hereby issues Registration in favour of DR. KULDEEP SALGOTRA to operate the following diagnostic radiology equipment located at PLOT NO. 1 AND 2, SECTOR 1, KAMOTHE OPPOSITE MC DONALD NAVI MUMBAI, MAHARASHTRA-410209 for Medical Diagnosis purposes.

Type of Equipment	Manufacturer	Model	Equipment Id
Radiography (Mobile)	M/s. Allengers Medical Systems Limited , India	Allengers-100	G-XR-64044

The MEDICAL SUPERINTENDENT, MAHATMA GANDHI MISSION HOSPITAL, KAMOTHE, NAVI MUMBAI and DR. KULDEEP SALGOTRA are hereby identified as the Employer and licensee respectively, for the purpose of assigning the responsibilities specified in the Atomic Energy (Radiation Protection) Rules, 2004, in respect of radiation protection of workers, public and environment because of operation of the above equipment.

The Employer and Licensee are responsible for,

- I. Ensuring compliance with the relevant provisions of the
 - i. Atomic Energy Act, 1962
 - ii. Atomic Energy (Radiation Protection) Rules, 2004;
 - iii. AERB Safety Code (AERB/SC/Med-2), 2001, Amendment 2012, and the revisions thereof
 - iv. All applicable Safety Codes, Guides issued by AERB for the above practice and regulatory documents issued by AERB from time to time.
 - v. Directives issued by Competent Authority from time to time.
- II. Ensuring compliance with terms and conditions stated overleaf.

Note:

This Registration is issued ONLY from the RADIATION SAFETY VIEW POINT. All other clearances shall be obtained from concerned state/central/local authorities as applicable.

Dr. Avinash U. Sonawane
Head, RSD

DR. KULDEEP SALGOTRA, MEDICAL SUPERINTENDENT
MAHATMA GANDHI MISSION HOSPITAL, KAMOTHE
PLOT NO. 1 AND 2, SECTOR 1, KAMOTHE OPPOSITE MC DONALD
NAVI MUMBAI, MAHARASHTRA-410209

CC: MEDICAL SUPERINTENDENT, MAHATMA GANDHI MISSION HOSPITAL, KAMOTHE, NAVI MUMBAI

Note: This document is also available at www.aerb.gov.in/elora



परमाणु ऊर्जा नियामक परिषद्, नियामक भवन, अणुसंश्लेषणनगर, मुंबई 400094 (महाराष्ट्र)
Atomic Energy Regulatory Board, Niyamak Bhavan, Anushuktinagar, Mumbai 400094 (Maharashtra)

वेबसाइट/Website: www.aerb.gov.in

दूरभाष/Tel: 91-22-2599 0656



An ISO 9001:2008
Organisation
फैक्स/Fax: 91-22-2599 0650



Case File Number: MH-20778-RF-XR-018

Issuance Date: 24/05/2016

Document Number: 16-LOEE-108090

Expiry Date: 24/05/2021

REGISTRATION FOR OPERATION OF MEDICAL DIAGNOSTIC X-RAY EQUIPMENT

In exercise of powers conferred under Section 16 and 17 as applicable of Atomic Energy Act, 1962 read in conjunction with Rule (3) of the Atomic Energy (Radiation Protection) Rules [AE(RP)R], 2004, the Atomic Energy Regulatory Board (AERB) hereby issues **Registration** in favour of Dr. PRAKASH PRABHAKARRAO DOKE to operate the following medical diagnostic x-ray equipment located at MAHATMA GANDHI MISSION HOSPITAL, KAMOTHE, PLOT NO. 1 AND 2, SECTOR 1, KAMOTHE OPPOSITE MC DONALD NAVI MUMBAI, MAHARASHTRA-410209 for medical diagnostic purpose.

Type of Equipment	Manufacturer	Model	Equipment ID
Radiography (Mobile)	M/s. Soma X-ray Company	Somex 100	G-XR-50230

The **MEDICAL SUPERINTENDENT, MAHATMA GANDHI MISSION HOSPITAL, KAMOTHE, NAVI MUMBAI** and **DR. PRAKASH PRABHAKARRAO DOKE** are hereby identified as the Employer and licensee respectively, for the purpose of assigning the responsibilities specified in the Atomic Energy (Radiation Protection) Rules, 2004, in respect of radiation protection of workers, public and environment because of operation of the above equipment.

The Employer and Licensee are responsible for,

- I. Ensuring compliance with the relevant provisions of the
 - i. Atomic Energy Act, 1962
 - ii. Atomic Energy (Radiation Protection) Rules, 2004;
 - iii. AERB Safety Code (AERB/SC/Med-2), 2001, Amendment 2012, and the revisions thereof
 - iv. All applicable Safety Codes, Guides issued by AERB for the above practice and regulatory documents issued by AERB from time to time.
 - v. Directives issued by Competent Authority from time to time.
- II. Ensuring compliance with terms and conditions stated overleaf.

Note:

This Registration is issued ONLY from the RADIATION SAFETY VIEW POINT. All other clearances shall be obtained from concerned state/central/local authorities as applicable.

Dr. Avinash U. Sonawane
Head, RSD

DR. PRAKASH PRABHAKARRAO DOKE
MAHATMA GANDHI MISSION HOSPITAL, KAMOTHE
PLOT NO. 1 AND 2, SECTOR 1, KAMOTHE OPPOSITE MC DONALD
NAVI MUMBAI, MAHARASHTRA-410209

Copy to: MEDICAL SUPERINTENDENT, MAHATMA GANDHI MISSION HOSPITAL, KAMOTHE, NAVI MUMBAI



वेबसाइट/Website: www.aerb.gov.in

Note: This document is also available at www.aerb.gov.in/elora
परमाणु ऊर्जा नियामक परिषद्, नियामक भवन, अणुशक्तिनगर, मुंबई 400094 (महाराष्ट्र)
Atomic Energy Regulatory Board, Niyamak Bhavan, Anushaktinagar, Mumbai 400094 (Maharashtra)

दूरभाष/Tel: 91-22-2599 0656



फैक्स/Fax: 91-22-2599 0650



Case File Number: MH-20778-RF-XR-017

Issue Date: 04/07/2016

Document Number: 16-LOP-117024

Expiry Date: 04/07/2021

REGISTRATION FOR OPERATION OF MEDICAL DIAGNOSTIC X-RAY EQUIPMENT

In exercise of powers conferred under Section 16 and 17 as applicable of Atomic Energy Act, 1962 read in conjunction with Rule (3) of the Atomic Energy (Radiation Protection) Rules {AE(RP)R}, 2004, the Atomic Energy Regulatory Board (AERB) hereby issues Registration in favour of DR. PRAKASH DOKE to operate the following diagnostic radiology equipment located at PLOT NO. 1 AND 2, SECTOR 1, KAMOTHE OPPOSITE MC DONALD NAVI MUMBAI, MAHARASHTRA-410209 for Medical Diagnosis purposes.

Type of Equipment	Manufacturer	Model	Equipment Id
Radiography (Mobile)	M/s. Allengers Medical Systems Limited , India	Allengers-100	G-XR-52987

The MEDICAL SUPERINTENDENT, MAHATMA GANDHI MISSION HOSPITAL, KAMOTHE, NAVI MUMBAI and DR. PRAKASH DOKE are hereby identified as the Employer and licensee respectively, for the purpose of assigning the responsibilities specified in the Atomic Energy (Radiation Protection) Rules, 2004, in respect of radiation protection of workers, public and environment because of operation of the above equipment.

The Employer and Licensee are responsible for,

- I. Ensuring compliance with the relevant provisions of the
 - i. Atomic Energy Act, 1962
 - ii. Atomic Energy (Radiation Protection) Rules, 2004;
 - iii. AERB Safety Code (AERB/SC/Med-2), 2001, Amendment 2012, and the revisions thereof
 - iv. All applicable Safety Codes, Guides issued by AERB for the above practice and regulatory documents issued by AERB from time to time.
 - v. Directives issued by Competent Authority from time to time.
- II. Ensuring compliance with terms and conditions stated overleaf.

Note:

This Registration is issued ONLY from the RADIATION SAFETY VIEW POINT. All other clearances shall be obtained from concerned state/central/local authorities as applicable.

Dr. Avinash U. Sonawane
Head, RSD

DR. PRAKASH DOKE, MEDICAL SUPERINTENDENT
MAHATMA GANDHI MISSION HOSPITAL, KAMOTHE
PLOT NO. 1 AND 2, SECTOR 1, KAMOTHE OPPOSITE MC DONALD
NAVI MUMBAI, MAHARASHTRA-410209

CC: MEDICAL SUPERINTENDENT, MAHATMA GANDHI MISSION HOSPITAL, KAMOTHE, NAVI MUMBAI

Note: This document is also available at www.aerb.gov.in/elora



परमाणु ऊर्जा नियामक परिषद्, नियामक भवन, अनुशक्तिनगर, मुंबई 400094 (महाराष्ट्र)
Atomic Energy Regulatory Board, Niyamak Bhavan, Anushaktinagar, Mumbai 400094 (Maharashtra)

वेबसाइट/Website: www.aerb.gov.in

दूरभाष/Tel: 91-22-2599 0656



फैक्स/Fax: 91-22-2599 0650



Case File Number: MH-20778-RF-XR-023

Issuance Date: 22/10/2016

Document Number: 16-LOEE-138979

Expiry Date: 22/10/2021

REGISTRATION FOR OPERATION OF MEDICAL DIAGNOSTIC X-RAY EQUIPMENT

In exercise of powers conferred under Section 16 and 17 as applicable of Atomic Energy Act, 1962 read in conjunction with Rule (3) of the Atomic Energy (Radiation Protection) Rules {AE(RP)R}, 2004, the Atomic Energy Regulatory Board (AERB) hereby issues **Registration** in favour of Dr. PRAKASH DOKE to operate the following medical diagnostic x-ray equipment located at MAHATMA GANDHI MISSION HOSPITAL, KAMOTHE, PLOT NO. 1 AND 2, SECTOR 1, KAMOTHE OPPOSITE MC DONALD NAVI MUMBAI, MAHARASHTRA-410209 for medical diagnostic purpose.

Type of Equipment	Manufacturer	Model	Equipment ID
Radiography (Mobile)	Wipro GE Healthcare Private Ltd.	Genius-60	G-XR-58317

The **MEDICAL SUPERINTENDENT, MAHATMA GANDHI MISSION HOSPITAL, KAMOTHE, NAVI MUMBAI** and **DR. PRAKASH DOKE** are hereby identified as the Employer and licensee respectively, for the purpose of assigning the responsibilities specified in the Atomic Energy (Radiation Protection) Rules, 2004, in respect of radiation protection of workers, public and environment because of operation of the above equipment.

The Employer and Licensee are responsible for,

- I. Ensuring compliance with the relevant provisions of the
 - i. Atomic Energy Act, 1962
 - ii. Atomic Energy (Radiation Protection) Rules, 2004;
 - iii. AERB Safety Code (AERB/SC/Med-2), 2001, Amendment 2012, and the revisions thereof
 - iv. All applicable Safety Codes, Guides issued by AERB for the above practice and regulatory documents issued by AERB from time to time.
 - v. Directives issued by Competent Authority from time to time.
- II. Ensuring compliance with terms and conditions stated overleaf.

Note:

This Registration is issued ONLY from the RADIATION SAFETY VIEW POINT. All other clearances shall be obtained from concerned state/central/local authorities as applicable.

Dr. Avinash U. Sonawane
Head, RSD

DR. PRAKASH DOKE
MAHATMA GANDHI MISSION HOSPITAL, KAMOTHE
PLOT NO. 1 AND 2, SECTOR 1, KAMOTHE OPPOSITE MC DONALD
NAVI MUMBAI, MAHARASHTRA-410209

Copy to: MEDICAL SUPERINTENDENT, MAHATMA GANDHI MISSION HOSPITAL, KAMOTHE, NAVI
MUMBAI

Note: This document is also available at www.aerb.gov.in/elora



परमाणु ऊर्जा नियामक परिषद्, नियामक भवन, अणुसक्तिनगर, मुंबई 400094 (महाराष्ट्र)
Atomic Energy Regulatory Board, Niyamak Bhavan, Anushaktinagar, Mumbai 400094 (Maharashtra)

वेबसाइट/Website: www.aerb.gov.in

दूरभाष/Tel: 91-22-2599 0656



फैक्स/Fax: 91-22-2599 0650



अध्यक्ष
Chairman

Case File Number: MH-20778-RF-XL-005

Issuance Date: 28/11/2016

Document Number: 14-RLXE-23955

Expiry Date: 28/11/2021

LICENSE FOR OPERATION OF MEDICAL DIAGNOSTIC X-RAY EQUIPMENT

In exercise of powers conferred under Section 16 and 17 as applicable of Atomic Energy Act, 1962 read in conjunction with Rule (3) of the Atomic Energy (Radiation Protection) Rules {AE(RP)R}, 2004, the Atomic Energy Regulatory Board (AERB) hereby issues Licence in favour of Dr. PRAKASH PRABHAKARRAO DOKE to operate the following medical diagnostic x-ray equipment located at MAHATMA GANDHI MISSION HOSPITAL, KAMOTHE, PLOT NO. 1 AND 2, SECTOR 1, KAMOTHE OPPOSITE MC DONALD NAVI MUMBAI, MAHARASHTRA-410209 for medical diagnostic purpose.

Type of Equipment	Manufacturer	Model	Equipment ID
Interventional Radiology	M/s. Philips India Limited	Allura Xper FD 10	G-XL-12741

The **MEDICAL SUPERINTENDENT, MAHATMA GANDHI MISSION HOSPITAL, KAMOTHE, NAVI MUMBAI** and **DR. PRAKASH PRABHAKARRAO DOKE** are hereby identified as the Employer and licensee respectively, for the purpose of assigning the responsibilities specified in the Atomic Energy (Radiation Protection) Rules, 2004, in respect of radiation protection of workers, public and environment because of operation of the above equipment.

The Employer and Licensee are responsible for,

- I. Ensuring compliance with the relevant provisions of the
 - i. Atomic Energy Act, 1962
 - ii. Atomic Energy (Radiation Protection) Rules, 2004;
 - iii. AERB Safety Code (AERB/SC/Med-2), 2001, Amendment 2012, and the revisions thereof
 - iv. All applicable Safety Codes, Guides issued by AERB for the above practice and regulatory documents issued by AERB from time to time.
 - v. Directives issued by Competent Authority from time to time.
- II. Ensuring compliance with terms and conditions stated overleaf.

Note:

This Licence is issued ONLY from the RADIATION SAFETY VIEW POINT. All other clearances shall be obtained from concerned state/central/local authorities as applicable.

(Competent Authority)

DR. PRAKASH PRABHAKARRAO DOKE
MAHATMA GANDHI MISSION HOSPITAL, KAMOTHE
PLOT NO. 1 AND 2, SECTOR 1, KAMOTHE OPPOSITE MC DONALD
NAVI MUMBAI, MAHARASHTRA-410209



परमाणु ऊर्जा नियामक परिषद्, नियामक भवन, अणुशक्तिनगर, मुंबई 400094 (महाराष्ट्र)
Atomic Energy Regulatory Board, Niyamak Bhavan, Anushaklinagar, Mumbai 400094 (Maharashtra)





Case File Number: MH-20778-RF-XR-009

Issuance Date: 02/10/2017

Document Number: 15-RLXE-51004

Expiry Date: 02/10/2022

REGISTRATION FOR OPERATION OF MEDICAL DIAGNOSTIC X-RAY EQUIPMENT

In exercise of powers conferred under Section 16 and 17 as applicable of Atomic Energy Act, 1962 read in conjunction with Rule (3) of the Atomic Energy (Radiation Protection) Rules {AE(RP)R}, 2004, the Atomic Energy Regulatory Board (AERB) hereby issues **Registration** in favour of Dr. PRAKASH PRABHAKARRAO DOKE to operate the following medical diagnostic x-ray equipment located at MAHATMA GANDHI MISSION HOSPITAL, KAMOTHE, PLOT NO. 1 AND 2, SECTOR 1, KAMOTHE OPPOSITE MC DONALD NAVI MUMBAI, MAHARASHTRA-410209 for medical diagnostic purpose.

Type of Equipment	Manufacturer	Model	Equipment ID
Radiography (Fixed)	M/s. Siemens Limited	Ergophos 4M Refurbished	G-XR-24205

The **MEDICAL SUPERINTENDENT, MAHATMA GANDHI MISSION HOSPITAL, KAMOTHE, NAVI MUMBAI** and **DR. PRAKASH PRABHAKARRAO DOKE** are hereby identified as the Employer and licensee respectively, for the purpose of assigning the responsibilities specified in the Atomic Energy (Radiation Protection) Rules, 2004, in respect of radiation protection of workers, public and environment because of operation of the above equipment.

The Employer and Licensee are responsible for,

- I. Ensuring compliance with the relevant provisions of the
 - i. Atomic Energy Act, 1962
 - ii. Atomic Energy (Radiation Protection) Rules, 2004;
 - iii. AERB Safety Code (AERB/SC/Med-2), 2001, Amendment 2012, and the revisions thereof
 - iv. All applicable Safety Codes, Guides issued by AERB for the above practice and regulatory documents issued by AERB from time to time.
 - v. Directives issued by Competent Authority from time to time.
- II. Ensuring compliance with terms and conditions stated overleaf.

Note:

This Registration is issued ONLY from the RADIATION SAFETY VIEW POINT. All other clearances shall be obtained from concerned state/central/local authorities as applicable.

Dr. Avinash U. Sonawane
Head, RSD

DR. PRAKASH PRABHAKARRAO DOKE
MAHATMA GANDHI MISSION HOSPITAL, KAMOTHE
PLOT NO. 1 AND 2, SECTOR 1, KAMOTHE OPPOSITE MC DONALD
NAVI MUMBAI, MAHARASHTRA-410209

Copy to: MEDICAL SUPERINTENDENT, MAHATMA GANDHI MISSION HOSPITAL, KAMOTHE, NAVI MUMBAI



वेबसाइट/Website: www.aerb.gov.in

Note: This document is also available at www.aerb.gov.in/elora
परमाणु ऊर्जा नियामक परिषद्, नियामक भवन, अणुशक्तिनगर, मुंबई 400094 (महाराष्ट्र)
Atomic Energy Regulatory Board, Niyamak Bhavan, Anushaktinagar, Mumbai 400094 (Maharashtra)

दूरभाष/Tel: 91-22-2599 0656



फैक्स/Fax: 91-22-2599 0650



Case File Number: MH-20778-RF-XR-010

Issuance Date: 22/06/2017

Document Number: 15-RLXE-51009

Expiry Date: 30/06/2022

REGISTRATION FOR OPERATION OF MEDICAL DIAGNOSTIC X-RAY EQUIPMENT

In exercise of powers conferred under Section 16 and 17 as applicable of Atomic Energy Act, 1962 read in conjunction with Rule (3) of the Atomic Energy (Radiation Protection) Rules {AE(RP)R}, 2004, the Atomic Energy Regulatory Board (AERB) hereby issues **Registration** in favour of Dr. PRAKASH DOKE to operate the following medical diagnostic x-ray equipment located at MAHATMA GANDHI MISSION HOSPITAL, KAMOTHE, PLOT NO. 1 AND 2, SECTOR 1, KAMOTHE OPPOSITE MC DONALD NAVI MUMBAI, MAHARASHTRA-410209 for medical diagnostic purpose.

Type of Equipment	Manufacturer	Model	Equipment ID
Radiography (Mobile)	M/s. Siemens Limited	Multimobile 2.5	G-XR-24207

The **MEDICAL SUPERINTENDENT, MAHATMA GANDHI MISSION HOSPITAL, KAMOTHE, NAVI MUMBAI** and **DR. PRAKASH DOKE** are hereby identified as the Employer and licensee respectively, for the purpose of assigning the responsibilities specified in the Atomic Energy (Radiation Protection) Rules, 2004, in respect of radiation protection of workers, public and environment because of operation of the above equipment.

The Employer and Licensee are responsible for,

- I. Ensuring compliance with the relevant provisions of the
 - i. Atomic Energy Act, 1962
 - ii. Atomic Energy (Radiation Protection) Rules, 2004;
 - iii. AERB Safety Code (AERB/SC/Med-2), 2001, Amendment 2012, and the revisions thereof
 - iv. All applicable Safety Codes, Guides issued by AERB for the above practice and regulatory documents issued by AERB from time to time.
 - v. Directives issued by Competent Authority from time to time.
- II. Ensuring compliance with terms and conditions stated overleaf.

Note:

This Registration is issued **ONLY** from the **RADIATION SAFETY VIEW POINT**. All other clearances shall be obtained from concerned state/central/local authorities as applicable.

Dr. Avinash U. Sonawane
Head, RSD

DR. PRAKASH DOKE
MAHATMA GANDHI MISSION HOSPITAL, KAMOTHE
PLOT NO. 1 AND 2, SECTOR 1, KAMOTHE OPPOSITE MC DONALD
NAVI MUMBAI, MAHARASHTRA-410209

Copy to: MEDICAL SUPERINTENDENT, MAHATMA GANDHI MISSION HOSPITAL, KAMOTHE, NAVI MUMBAI

Note: This document is also available at www.aerb.gov.in/elora



परमाणु ऊर्जा नियामक परिषद्, नियामक भवन, अणुशक्तिनगर, मुंबई 400094 (महाराष्ट्र)
Atomic Energy Regulatory Board, Niyamak Bhavan, Anushaktinagar, Mumbai 400094 (Maharashtra)

वेबसाइट/Website: www.aerb.gov.in

दूरभाष/Tel: 91-22-2599 0656



फोन/फैक्स: 91-22-2599 0650



Case File Number: MH-20778-RF-XR-020

Issue Date: 04/07/2016

Document Number: 16-LOP-117023

Expiry Date: 04/07/2021

REGISTRATION FOR OPERATION OF MEDICAL DIAGNOSTIC X-RAY EQUIPMENT

In exercise of powers conferred under Section 16 and 17 as applicable of Atomic Energy Act, 1962 read in conjunction with Rule (3) of the Atomic Energy (Radiation Protection) Rules (AE(RP)R), 2004, the Atomic Energy Regulatory Board (AERB) hereby issues Registration in favour of DR. PRAKASH DOKE to operate the following diagnostic radiology equipment located at PLOT NO. 1 AND 2, SECTOR 1, KAMOTHE OPPOSITE MC DONALD NAVI MUMBAI, MAHARASHTRA-410209 for Medical Diagnosis purposes.

Type of Equipment	Manufacturer	Model	Equipment Id
C-Arm	ALLENGERS MEDICAL SYSTEMS LTD., India	Allengers-HF-49R	G-XR-52830

The MEDICAL SUPERINTENDENT, MAHATMA GANDHI MISSION HOSPITAL, KAMOTHE, NAVI MUMBAI and DR. PRAKASH DOKE are hereby identified as the Employer and licensee respectively, for the purpose of assigning the responsibilities specified in the Atomic Energy (Radiation Protection) Rules, 2004, in respect of radiation protection of workers, public and environment because of operation of the above equipment.

The Employer and Licensee are responsible for,

- I. Ensuring compliance with the relevant provisions of the
 - i. Atomic Energy Act, 1962
 - ii. Atomic Energy (Radiation Protection) Rules, 2004;
 - iii. AERB Safety Code (AERB/SC/Med-2), 2001, Amendment 2012, and the revisions thereof
 - iv. All applicable Safety Codes, Guides issued by AERB for the above practice and regulatory documents issued by AERB from time to time.
 - v. Directives issued by Competent Authority from time to time.
- II. Ensuring compliance with terms and conditions stated overleaf.

Note:

This Registration is issued ONLY from the RADIATION SAFETY VIEW POINT. All other clearances shall be obtained from concerned state/central/local authorities as applicable.

Dr. Avinash U. Sonawane
Head, RSD

DR. PRAKASH DOKE, MEDICAL SUPERINTENDENT
MAHATMA GANDHI MISSION HOSPITAL, KAMOTHE
PLOT NO. 1 AND 2, SECTOR 1, KAMOTHE OPPOSITE MC DONALD
NAVI MUMBAI, MAHARASHTRA-410209

CC: MEDICAL SUPERINTENDENT, MAHATMA GANDHI MISSION HOSPITAL, KAMOTHE, NAVI MUMBAI

Note: This document is also available at www.aerb.gov.in/elora



परमाणु ऊर्जा नियामक परिषद्, नियामक भवन, अणुसक्तिनगर, मुंबई 400094 (महाराष्ट्र)
Atomic Energy Regulatory Board, Niyamak Bhavan, Anushaktinagar, Mumbai 400094 (Maharashtra)

वेबसाइट/Website: www.aerb.gov.in

दूरभाष/Tel: 91-22-2599 0650



फैक्स/Fax: 91-22-2599 0650



Case File Number: MH-20778-RF-XR-004

Issuance Date: 27/08/2017

Document Number: 15-RLXE-51010

Expiry Date: 27/08/2022

REGISTRATION FOR OPERATION OF MEDICAL DIAGNOSTIC X-RAY EQUIPMENT

In exercise of powers conferred under Section 16 and 17 as applicable of Atomic Energy Act, 1962 read in conjunction with Rule (3) of the Atomic Energy (Radiation Protection) Rules [AE(RP)R], 2004, the Atomic Energy Regulatory Board (AERB) hereby issues **Registration** in favour of Dr. PRAKASH PRABHAKARRAO DOKE to operate the following medical diagnostic x-ray equipment located at MAHATMA GANDHI MISSION HOSPITAL, KAMOTHE, PLOT NO. 1 AND 2, SECTOR 1, KAMOTHE OPPOSITE MC DONALD NAVI MUMBAI, MAHARASHTRA-410209 for medical diagnostic purpose.

Type of Equipment	Manufacturer	Model	Equipment ID
C-Arm	M/s. Allengers Medi Systems	Allengers HF-49	G-XR-12737

The **MEDICAL SUPERINTENDENT, MAHATMA GANDHI MISSION HOSPITAL, KAMOTHE, NAVI MUMBAI** and **DR. PRAKASH PRABHAKARRAO DOKE** are hereby identified as the Employer and licensee respectively, for the purpose of assigning the responsibilities specified in the Atomic Energy (Radiation Protection) Rules, 2004, in respect of radiation protection of workers, public and environment because of operation of the above equipment.

The Employer and Licensee are responsible for,

- I. Ensuring compliance with the relevant provisions of the
 - i. Atomic Energy Act, 1962
 - ii. Atomic Energy (Radiation Protection) Rules, 2004;
 - iii. AERB Safety Code (AERB/SC/Med-2), 2001, Amendment 2012, and the revisions thereof
 - iv. All applicable Safety Codes, Guides issued by AERB for the above practice and regulatory documents issued by AERB from time to time.
 - v. Directives issued by Competent Authority from time to time.
- II. Ensuring compliance with terms and conditions stated overleaf.

Note:

This Registration is issued **ONLY** from the **RADIATION SAFETY VIEW POINT**. All other clearances shall be obtained from concerned state/central/local authorities as applicable.

Dr. Avinash U. Sonawane
Head, RSD

DR. PRAKASH PRABHAKARRAO DOKE
MAHATMA GANDHI MISSION HOSPITAL, KAMOTHE
PLOT NO. 1 AND 2, SECTOR 1, KAMOTHE OPPOSITE MC DONALD
NAVI MUMBAI, MAHARASHTRA-410209

Copy to: MEDICAL SUPERINTENDENT, MAHATMA GANDHI MISSION HOSPITAL, KAMOTHE, NAVI MUMBAI

Note: This document is also available at www.aerb.gov.in/elora



परमाणु ऊर्जा नियामक परिषद्, नियामक भवन, अणुसक्तिनगर, मुंबई 400094 (महाराष्ट्र)
Atomic Energy Regulatory Board, Niyamak Bhavan, Anushaktinagar, Mumbai 400094 (Maharashtra)





Case File Number: MH-20778-RF-XR-027

Issuance Date: 31/01/2018

Document Number: 18-LOEE-251716

Expiry Date: 31/01/2023

REGISTRATION FOR OPERATION OF MEDICAL DIAGNOSTIC X-RAY EQUIPMENT

In exercise of powers conferred under Section 16 and 17 as applicable of Atomic Energy Act, 1962 read in conjunction with Rule (3) of the Atomic Energy (Radiation Protection) Rules {AE(RP)R}, 2004, the Atomic Energy Regulatory Board (AERB) hereby issues **Registration** in favour of Dr. PRAKASH DOKE to operate the following medical diagnostic x-ray equipment located at MAHATMA GANDHI MISSION HOSPITAL, KAMOTHE, PLOT NO. 1 AND 2, SECTOR 1, KAMOTHE OPPOSITE MC DONALD NAVI MUMBAI, MAHARASHTRA-410209 for medical diagnostic purpose.

Type of Equipment	Manufacturer	Model	Equipment ID
C-Arm	ALLENGERS MEDICAL SYSTEMS LIMITED	HF49-SR	G-XR-77479

The **MEDICAL SUPERINTENDENT, MAHATMA GANDHI MISSION HOSPITAL, KAMOTHE, NAVI MUMBAI** and **DR. PRAKASH DOKE** are hereby identified as the Employer and licensee respectively, for the purpose of assigning the responsibilities specified in the Atomic Energy (Radiation Protection) Rules, 2004, in respect of radiation protection of workers, public and environment because of operation of the above equipment.

The Employer and Licensee are responsible for,

- I. Ensuring compliance with the relevant provisions of the
 - i. Atomic Energy Act, 1962
 - ii. Atomic Energy (Radiation Protection) Rules, 2004;
 - iii. AERB Safety Code (AERB/SC/Med-2), 2001, Amendment 2012, and the revisions thereof
 - iv. All applicable Safety Codes, Guides issued by AERB for the above practice and regulatory documents issued by AERB from time to time.
 - v. Directives issued by Competent Authority from time to time.
- II. Ensuring compliance with terms and conditions stated overleaf.

Note:

This Registration is issued ONLY from the RADIATION SAFETY VIEW POINT. All other clearances shall be obtained from concerned state/central/local authorities as applicable.

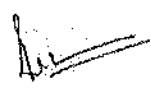
Dr. P. K. Dash Sharma
Head, RSD

DR. PRAKASH DOKE

MAHATMA GANDHI MISSION HOSPITAL, KAMOTHE
PLOT NO. 1 AND 2, SECTOR 1, KAMOTHE OPPOSITE MC DONALD
NAVI MUMBAI, MAHARASHTRA-410209

Copy to: MEDICAL SUPERINTENDENT, MAHATMA GANDHI MISSION HOSPITAL, KAMOTHE, NAVI
MUMBAI

Note: This document is also available at www.aerb.gov.in/elora



परमाणु ऊर्जा नियामक परिषद्, नियामक भवन, अणुशक्तिनगर, मुंबई 400094 (महाराष्ट्र)
Atomic Energy Regulatory Board, Niyamak Bhavan, Anushaktinagar, Mumbai 400094 (Maharashtra)

वेबसाइट/Website: www.aerb.gov.in

दूरभाष/Tel: 91-22-2599 0656



फोन/फैक्स: 91-22-2599 0650

Radiation Safety Certificate

भारत सरकार
परमाणु ऊर्जा नियामक परिषद्
विकिरण संरक्षा प्रभाग



GOVERNMENT OF INDIA
ATOMIC ENERGY REGULATORY BOARD
RADIOLOGICAL SAFETY DIVISION

Case File Number: MH-25439-RF-XR-020

Issuance Date: 07/04/2017

Document Number: 17-LOEE-177549

Expiry Date: 07/04/2022

REGISTRATION FOR OPERATION OF MEDICAL DIAGNOSTIC X-RAY EQUIPMENT

In exercise of powers conferred under Section 16 and 17 as applicable of Atomic Energy Act, 1962 read in conjunction with Rule (3) of the Atomic Energy (Radiation Protection) Rules {AE(RP)R}, 2004, the Atomic Energy Regulatory Board (AERB) hereby issues **Registration** in favour of Dr. AJIT SHROFF to operate the following medical diagnostic x-ray equipment located at MAHATMA GANDHI MISSION HOSPITAL, N 6 CIDCO, AURANGABAD AURANGABAD, MAHARASHTRA-431003 for medical diagnostic purpose.

Type of Equipment	Manufacturer	Model	Equipment ID
C-Arm	M/s Siemens Healthcare Private Limited	Multimobil-5C	G-XR-66177

The **DEAN, MAHATMA GANDHI MISSION HOSPITAL, AURANGABAD** and **DR. AJIT SHROFF** are hereby identified as the Employer and licensee respectively, for the purpose of assigning the responsibilities specified in the Atomic Energy (Radiation Protection) Rules, 2004, in respect of radiation protection of workers, public and environment because of operation of the above equipment. **AJIT GOVINDDAS SHROFF** is the designated Radiological Safety Officer (RSO).

The Employer and Licensee are responsible for,

- I. Ensuring compliance with the relevant provisions of the
 - i. Atomic Energy Act, 1962
 - ii. Atomic Energy (Radiation Protection) Rules, 2004;
 - iii. AERB Safety Code (AERB/SC/Med-2), 2001, Amendment 2012, and the revisions thereof
 - iv. All applicable Safety Codes, Guides issued by AERB for the above practice and regulatory documents issued by AERB from time to time.
 - v. Directives issued by Competent Authority from time to time.
- II. Ensuring compliance with terms and conditions stated overleaf.

Note:

This Registration is issued ONLY from the RADIATION SAFETY VIEW POINT. All other clearances shall be obtained from concerned state/central/local authorities as applicable.

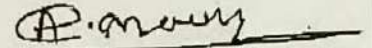
Dr. Avinash U. Sonawane
Head, RSD

DR. AJIT SHROFF
MAHATMA GANDHI MISSION HOSPITAL
N 6 CIDCO, AURANGABAD
AURANGABAD, MAHARASHTRA-431003
Copy to: DEAN, MAHATMA GANDHI MISSION HOSPITAL, AURANGABAD



वेबसाइट/Website: www.aerb.gov.in

Note: This document is also available at www.aerb.gov.in/elora
परमाणु ऊर्जा नियामक परिषद्, नियामक भवन, अणुशक्तिनगर, मुंबई 400094 (महाराष्ट्र)
Atomic Energy Regulatory Board, Niyamak Bhavan, Anushaktinagar, Mumbai 400094 (Maharashtra)

दूरभाष/Tel: 91-22-2599 0656



फैक्स/Fax: 91-22-2599 0650

**HAZARDOUS
CHEMICAL
DISPOSAL SOP**

Waste Recycling system:

- 1) Sewage treatment Plant
- 2) Effluent treatment Plant
- 3) Water treatment Plant

Sewage treatment Plant

Effluent treatment Plant

**OPERATION &
MAINTENANCE MANUAL**

OF

SEWAGE TREATMENT PLANT

FOR

M/s. Mahatma Gandhi Mission

AT

Aurandabad, Maharashtra

BY

AQUACHEM ENVIRO ENGINEERS PVT LTD

104, SIDDHACHAL, NEXT TO COSMOS BANK, HANUMAN ROAD, VILE
PARLE (E), MUMBAI - 400 057

Prepared on: 28/01/2016

Prepared by: VDT

Checked by: MMN

Revised on:



CONTENTS

Chapter No.	Topic
I	Introduction
II	Design Criteria
III	Process Description and Methodology
III	Unit List
IV	Equipment List
V	Drawings
VI	Test Certificates & Manuals of Equipments



CHAPTER I

INTRODUCTION

M/s. Mahatma Gandhi Mission (MGM) is having a facility for Hospital in CIDCO area, Aurangabad . During the daily activities of Hospital various domestic/ effluent streams are generated from the Canteen & Toilet and Hospital departments which are directed to the ETP/STP. The domestic streams generated in the Hospital are treated in the sewage treatment plant to meet the discharge norms. Effluent generated in various departments of Hospital comes to ETP side where after giving Primary Treatment it is going ahead to STP for next treatment.

M/s Aquachem Enviro Engineers Pvt. Ltd is the turnkey contractor for supply and erection of ETP/STP. Entire ETP is designed for 30 m³/day capacity followed by STP having capacity of 600 m³/day.



SECTION II

DESIGN CRITERIA

POLLUTION LOAD

Effluent/Sewage Quantity Generated:

Based on the data given by MGM Hospital, the Sewage water generation will be 600 m³/day and Effluent generation will be 30 m³/day.

Following are the design parameters for the STP 600 m³/day and ETP 30 m³/day and the operating philosophy is as given under in section III.

Design Parameters for ETP

Parameter	Unit	Raw Sewage Characteristics	Treated Sewage Characteristics
Flow	m ³ /day	30	30
pH	--	6-8	6.5-8.5
TSS	mg/lit	300	>5
BOD	mg/lit	300	>10
COD	mg/lit	700	>50

Design Parameters for STP

Parameter	Unit	Raw Sewage Characteristics	Treated Sewage Characteristics
Flow	m ³ /day	600	600
pH	--	5.5-8	6.5-8.5
TSS	mg/lit	300-400	>5
BOD	mg/lit	300-400	>10
COD	mg/lit	700-900	>50
Oil & Grease	mg/lit	30-50	Nil

Notes:

- All parameters are mg/lit except pH
- The Basis of design is as per the details given by client.
- There is no separate treatment provided for TDS removal in STP. Therefore, as specified, TDS in the sewage will remain un-changed.



SECTION III

PROCESS SCHEME AND DESCRIPTION

Effluent Treatment Plant (ETP) will consists of following units,

1. Equalization Tank
2. Flash Mixer
3. Settling Tank

Sewage Treatment plant (STP) will consist of following units,

1. Sewage Collection Tank
2. Bar Screen Chamber
3. Oil & Grease Trap
4. Aeration Tank
5. Secondary Clarifier
6. Chlorine Contact Tank
7. Sludge Holding Tank
8. Final Water Holding Tank
9. Final Treated Water Tank

For Proposed Scheme and Description:

ETP-

1. **Equalization Tank:** Raw Effluent generated from various departments of Hospital is directed by gravity flow to ETP Equalization Tank. Here all effluent is getting equalized. After equalization effluent will pumped to Flash Mixer Chamber
2. In **Flash Mixer** chemical dosing is happened to raw effluent stream. Alum and Poly dosing is carried out so as to happen chemical reaction and flocculation treatment. After flocculation effluent enters to Primary Settling Tank
3. In **Primary Settling Tank** all suspended matter present in raw effluent get settled down at the bottom and supernatant overflows ahead to Aeration (MBBR) tank for Secondary treatment purpose at STP side.



STP-

1. Sewage Collection Tank- 1 no. is provided to equalize the sewage effluent. Coarse aeration system viz. air grid, blower etc. is provided for pre aeration and to keep solids in suspension. Then, equalized sewage is pumped to the Aeration Tank for Biological treatment.

2. Bar Screen chamber:

Raw sewage effluent is directed to the first treatment unit of STP i.e. Bar Screen Chamber for removal floating matters. Screen chamber comprises of SS screen. The floating matter is removed regularly from the screens manually. Sewage effluent is then entered to Aeration (MBBR) Tank by Gravity.

SECONDARY (BIOLOGICAL) TREATMENT:

Biological treatment (Activated sludge treatment) with MBBR media and diffused aeration is provided to degrade the organic matter in the sewage with the help of bacteria.

Biological treatment, consist of following units;

- **Aeration tank- 1 no with MBBR Media**
- **Diffused aeration system- Diffusers, Air blowers – 2 nos.**
- **Secondary Clarifier – 1 no.**
- **Sludge recycle pumps– 2 nos.**

In Aeration tank , Mixed Liquor Suspended Solids (MLSS) is developed due to presence of Bacteria in sewage and oxygen. The oxygen required for the bacterial growth is supplied through Diffused Aeration system by diffusers connected to the Air blower.

After biological treatment, mixed liquor from Aeration Tank (AT) enters by gravity into adjacent Secondary Settling Tank (SST) for solid liquid separation.

Sludge from the bottom of the SST is recycled to AT to maintain MLSS, by providing Sludge Pumps (SP).

Excess sludge is discharged through Filter Press and disposed off suitably.

Sec. Treated effluent then enters by gravity to Chlorine Contact Tank– 1 no.



TERTIARY TREATMENT:

Dual Media filter

Clarified Water from CCT is pumped to Dual Media Filter (DMF) – 1 no. for removal solids and so as final finishing Treatment purpose.

Backwash from filter is directed to the Sewage Collection Tank and filtered eater goes ahead to Existing old Treated Water Holding Tank from where it will pumped to Final Treated Water Collection Tank.

TERTIARY TREATMENT

Source : Effluent/Sewage after biological treatment
(after secondary Settling Tank)

Treatment given : Hypochlorite dosing.

Objective of treatment : • Chlorination/disinfection, removal of traces of suspended solids, removal of refractory organics/polishing Removal of BOD/COD from the effluents

Resources involved : • Chlorine contact Tank
• Filter Feed pumps
• Multi grade filter
• Hypo dosing system
• Final Treated Water Tank

Effluents after secondary treatment are directed to tertiary treatment.

Chlorine contact tank is provided for chlorine dosing. Effluent is pumped to Multi grade filter using Filter feed pumps.

From outlet of MGF filter, treated effluent is directed to Treated Water Tank.

Filtration

The effluent will pass through Multi grade filter for removal of traces of suspended solids in the effluent.

OPERATION MANUAL FOR MULTI GRADE FILTER

INTRODUCTION:



Vertical Multi Grade Filters are designed for efficient working because of properly fabricated distributors. They are meant for increased flow rates compared to Gravity Sand Filters and can treat water of turbidity up to 50 NTU. Fine grade of Filter Sand ensure trapping of suspended solids efficiently. The sand bed is supported by other graded filter media through which water uniformly flows.

SPECIFICATION:

These filters are basically consists of a fabricated MS pressure vessel internally painted with anticorrosive paint. The filter consists of necessary nozzles, bottom collecting system and top bell mouth or a header, one charge of filter media. Externally, the unit is provided with frontal pipe-work, a set of valves, gaskets, pressure gauge, sample cocks, and air release pipe.

INSTALLATION:

A suitable concrete plinth of height given in the drawing shall be prepared and the vessel is kept on the foundation putting necessary foundation bolts in the foundation pockets. The vessel is plumbed properly and the foundation bolts are grouted. The top cover is opened and filter media shall be charged into it. Piping connection shall be completed as per the diagram given.

OPERATION:

NORMAL WORKING:

Before operation of the filter ensure that it has water above the sand bed level. Now open valves V1 and V2. Adjust valve V1 to get desired flow rate at the outlet. The water is flowing from top of the bottom inside the vessel. The suspended particles remain of the top of sand layer. The water flowing from below is collected at the bottom and then comes out through the outlet valves filtering all suspended solids.

open air release valves while starting the unit and close the valve when all air is released from vessel and water starts coming out from the same.



SEWAGE TREATMENT PLANT OF MGM, AURANGABAD

As the dirt accumulates at the top of sand layer, the pressure difference at inlet and outlet increases. When the pressure difference exceeds 0.5 kg/cm^2 , the unit requires back-washing.

BACK WASHING OPERATION:

All the valves are closed. Open valves V3, V4 and V6. When all the air from air release pipe comes out, close valves V6. Now adjust valves V4 to get correct flow rate. The dirty water coming from V4 will go to the drain. Continue this for 5 to 10 minutes till water becomes clear like raw water. Thereafter close valves V3 and V4.

DOWN RINSE:

Open valve V1 and V5. Adjust valves V1 and V5 so that to get slightly more flow than the normal flow rate. Continue the operation till clear water of turbidity below 5 NTU is obtained. After that, close valve V5 and open valve V2 which connects to activated carbon filter. The unit is ready for normal working.

CHECK LIST:

- Always open the air release valve during initial start up of filters operation. Remove air completely and then only close the air valve.
- During back wash operation, never open the inlet valve of the filters.
- Check the pressure drop across the filters. When pressure drop is more than 0.5 kg/cm^2 or when effluent quality is not acceptable, back wash the filter.
- Never pump the effluents at very high rate. Loop line for the pumps is provided to control the flow rate.
- Follow the instructions as given earlier for other equipment operations.



UNIT / EQUIPMENT LIST OF EFFLUENT TREATMENT PLANT

A. UNITS (CIVIL- CLIENT'S SCOPE)

SR. NO.	DESCRIPTION	SIZE CAPACITY	QTY	MOC
1.	Raw sewage collection tank	10 m x10 m x 3m SWD	1	RCC M30
2.	Screen chamber	1 m x 1 m x 0.75 m SWD	1	RCC M30
3.	Oil and grease tank	2 m x 1 m x 1 m SWD	1	RCC M30
4.	MBBR tanks	8 m x 8 m x4.2m SWD	1	RCC M30
5.	Secondary clarifier	6.5m dia X 3m swd		
6.	Chlorine contact tank with baffles	3 m x 3 m x 3 m SWD	1	RCC M30
7.	Treated effluent tank	Existing to be used		
8.	Sludge tank	2 m x 2m x 2.5 m SWD	1	RCC M30
9.	MCC Room	5 m x 3 m	1	RCC / Brick
10.	Blower/chemical /Pumps room	Suitable	1	RCC/Brick
11.	Filter press shed	4 m x 4 m	1	RCC / Brick
12.	Equipment Foundations	Suitable	lot	Suitable
13.	Puddles, inserts plates, etc	Suitable	lot	Suitable
14.	Platform, railings, approach ladders, concrete blocks	Suitable	lot	Suitable

B. EQUIPMENT LIST - AEEPL's SCOPE

SR. NO.	DESCRIPTION	SIZE CAPACITY	QTY	MOC	KW
I	ETP				
1.	Effluent Transfer Pumps	1.5 m ³ /hr@10m head	2	CI	--
2.	Flash Mixer Agitator	1 m x 1 m x 1 m SWD	1	SS	--
3	Tube Settler	2 m x 2 m x 2.5 m SWD	1	MSEP	--
II	STP				
1.	Bar Screen	Suitable	1	SS	--
2.	Sewage transfer pumps	30 m ³ /hr @ 10m head	2	CI,	3.73
4.	Oil belt skimmer	Suitable	1	PP belt	0.375
5.	MBBR tank blowers- without Acoustic hood	350 m ³ /hr @ 0.55 kg/cm ² head	2	CI	7.5
6.	Secondary clarifier mechanism	Suitable	1	MSEP	0.375
7.	MBBR media	Suitable	Lot	PP	--
8.	Diffusers MBBR tank	Suitable	lot	Suitable	--
9.	Sludge recycle pump	20 m ³ /hr @ suitable head	2	CI,	2.0
10	Chlorine tank	1 m ³ capacity	1	suitable	--
11	Dosing pumps	0.20 LPH electronic type	2	PP	0.5
12.	Filter feed pumps	25 m ³ /hr @ suitable head	2	CI	2.0
13.	Multi grade Filter	1.5 m X1.5 HOS	1	MSEP	--

**SEWAGE TREATMENT PLANT OF MGM, AURANGABAD**

14.	Airline to be provided for Sludge sump	Suitable	1	HDPE	--
15.	Filter press feed pumps	3m ³ /hr @ 60 m head	2	CI, Screw type	1.5
12.	Filter Press	To handle sludge in 16 hrs operation	1		0.5
13.	Dewatering poly dosing tanks with agitators	100 litre capacity	2	HDPE / SS	0.5
14.	Dewatering poly dosing pumps	0.20 LPH (Electronic type)	2	PP	0.5

Power Installed - 34 KW
Power consumption- 432 KWH/day
Total Area required- about 434 m²

INSTRUMENTATION LIST (IN AQUACHEM SCOPE) (WITHIN BATTERY LIMITS)				
SR. NO	DESCRIPTION	CAPACITY/SIZE	QTY	MOC
1.	Pressure Gauges	Bourdon / Diaphragm	Lot	Suitable
2.	Level Switches	Magnetic Type	Lot	Suitable
3.	Flow meter	Inlet line -	1	Suitable



SECTION V

DRAWINGS

LIST OF DRAWINGS

Sr. No.	Drawing No.	Drawing Title
1.	C- 1494/103	Process Flow Diagram
2.	C-1494/102	Process & Instrumentation Diagram for STP/ETP

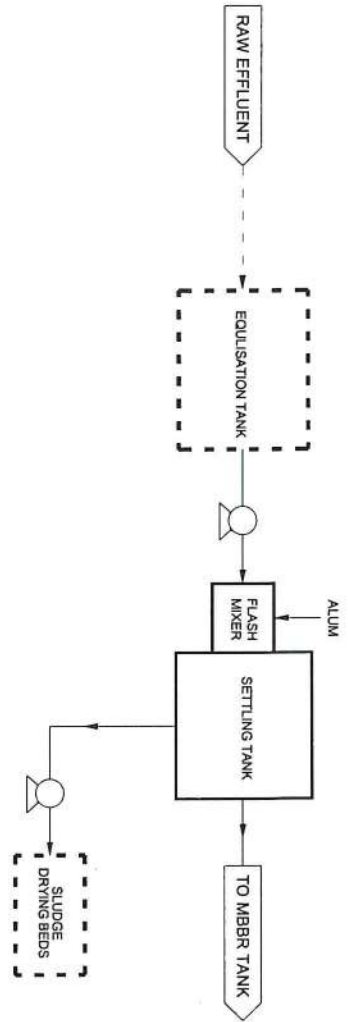

EFFLUENT TREATMENT PLANT

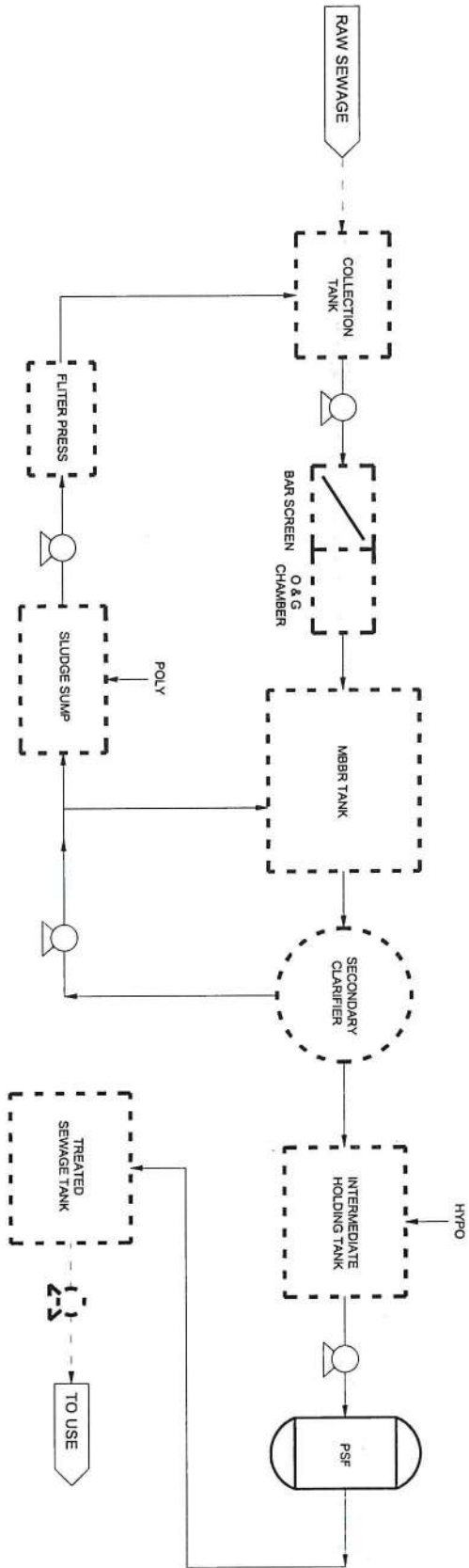

SEWAGE TREATMENT PLANT

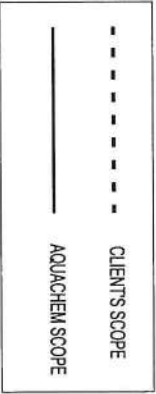

Rev/No	Revision note	Date	Signature	Checked

AQUACHEM ENVIRO ENGINEERS PVT. LTD.
 HANUMAN ROAD, VILE PARLE (E), MUMBAI - 400 027
 PHONE: (022) 2 811 9788/8789/2 810 1317/2 819 7723 FAX: (022) 2 010 2018

DRAWN	KABIN	PROJECT	:- SEWAGE & EFFLUENT TREATMENT PLANT
CHECKED	TRG	CLIENT	:- M/S. MGA
APPROVED	MAN	LOCATION	:- AURANGABAD
DATE	1.11.2014	CONSULTANTS	:- M/S. AQUACHEM ENVIRO ENGINEERS PVT. LTD.
SCALE	M/S	TITLE	:- PROCESS FLOW DIAGRAM FOR SEWAGE & EFFLUENT TREATMENT PLANT
SHEET	1 OF 1	DRAWING NO	:- C-1494-103



SECTION VI

Test Certificates & Manuals of Equipment

Test Certificates and Manuals of Equipments are provided in soft copies.

THIS PRINT IS THE PROPERTY OF "AQUACHEM ENVIRO ENGINEERS PVT. LTD." IT IS TO BE USED ONLY FOR THE PURPOSE FOR WHICH IT WAS LENT AND MUST NOT BE USED IN ANY WAY DETRIMENTAL TO THE INTEREST OF THIS COMPANY & IS SUBJECT TO RETURN ON DEMAND.

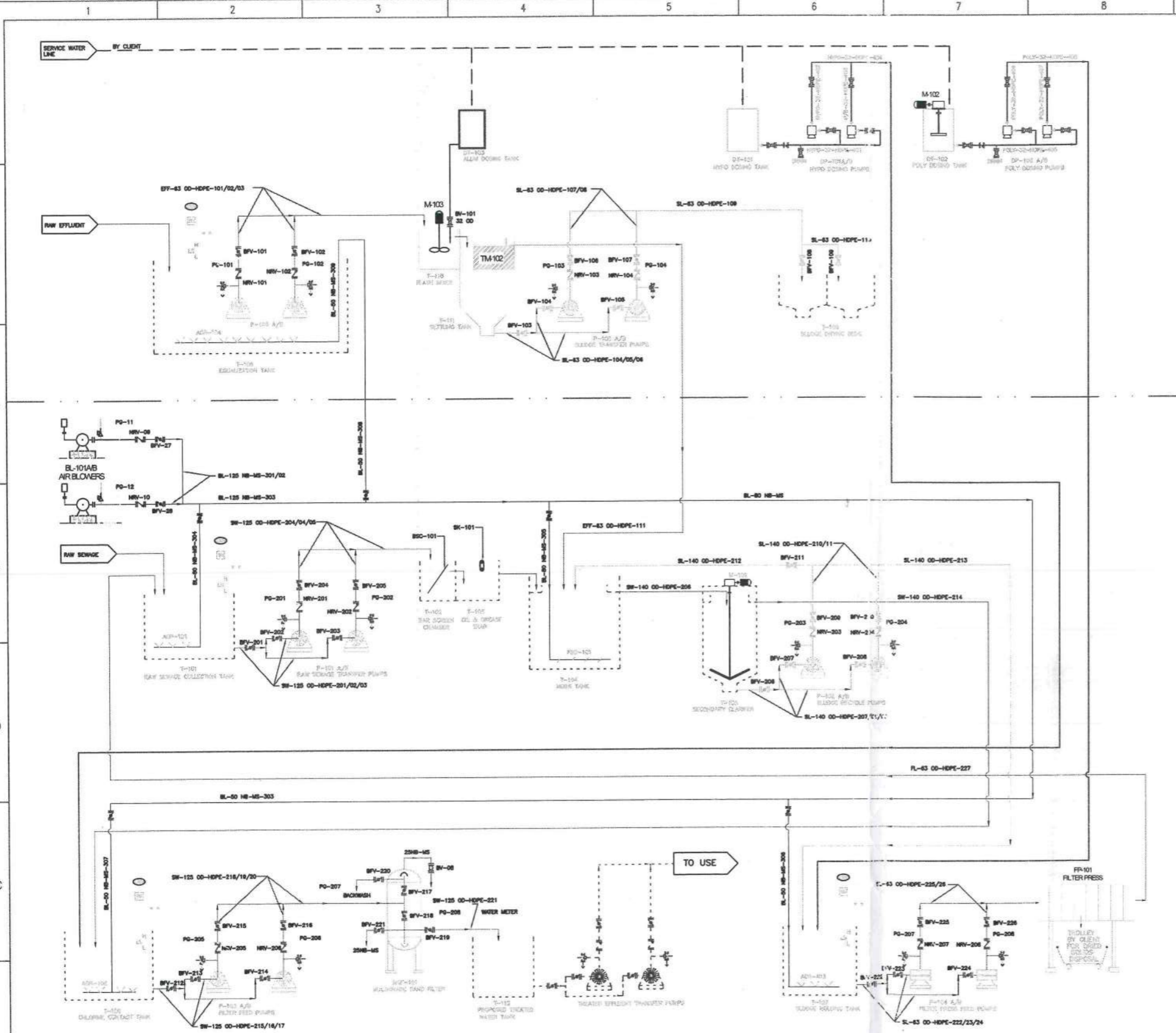

STP UNIT LIST

TAG No.	DESCRIPTION	CAPACITY	QTY.	MOC	SIZE
T-101	RAW SEWAGE COLLECTION TANK	200 m ³	1	RCC M30	15m x 10m x 2m SWD +0.5m
T-102	BAR SCREEN CHAMBER	0.75 m ³	1	RCC M30	1m x 1m x 0.75m SWD +0.5m
T-103	OIL & GREASE TRAP	2 m ³	1	RCC M30	2m x 1m x 1m SWD +0.5m
T-104	MGR TANK	28.5 m ³	1	RCC M30	8m x 2m x 4.2m SWD +0.5m
T-105	SECONDARY CLARIFIER	89.54 m ³	1	RCC M30	5.3m x 3m x 3m SWD +0.5m
T-108	CHLORINE CONTACT TANK	27 m ³	1	RCC M30	3m x 3m x 3m SWD +0.5m
T-107	SLUDGE HOLDING TANK	10 m ³	1	RCC M30	2m x 2m x 2.5m SWD +0.5m
T-112	PROPOSED WATER TANK	504 m ³	1	RCC M30	18m x 8m x 3.5m SWD +0.5m

ETP UNIT LIST

TAG No.	DESCRIPTION	CAPACITY	QTY.	MOC	SIZE
T-106	EQUALISATION TANK	12 m ³	1	RCC M30	3m x 2m x 2m SWD +3.5m
T-109	SLUDGE DRYING BED (EXISTING)	4 m ²	2	BRICK	2m x 2m
T-110	FLASH MIXER	1 m ³	1	MSP	1m x 1m x 1m SWD +0.5m
T-111	SETTLING TANK	10 m ³	1	MSP	2m x 2m x 2.5m SWD +0.5m

STP EQUIPMENT LIST

TAG No.	DESCRIPTION	QTY.	MOC	SIZE
BSC-101	BAR SCREEN	1	SS	SUITABLE
AGR-101/102/103	AERATION GRIDS FOR SEWAGE COLLECTION TANK, CHLORINE CONTACT TANK & SLUDGE HOLDING TANK	LOT	HDPE	SUITABLE
SK-101	BELT SKIMMER FOR OIL REMOVAL			
P-101 A/B	SEWAGE TRANSFER PUMPS	2	CI	30m ³ /hr @ 10-12 m head
P-102 A/B	SLUDGE RECYCLE PUMPS	2	CI	20m ³ /hr @ 10-12 m head
FDG-101	RETRIEVABLE DIFFUSERS SYSTEM FOR AERATION TANK	LOT	EPDM	#50 mm x 1m LONG
BL-101 A/B	AIR BLOWERS FOR AERATION GRIDS IN CHLORINE CONTACT TANK & MGR TANK	2	CI	600m ³ /hr @ 0.55 kg/cm ²
MED-101	MEDIA FOR MGR TANK	LOT	PP/PVC	SUITABLE FOR VOLUME OF TANK
P-103 A/B	FILTER FEED PUMPS	2	CI	25m ³ /hr @ 10-12 m head
MGF-101	MULTIGRADE SAND FILTER	1	MSEP	#1500 x 1500 HT.
M-101	SECONDARY CLARIFIER MECHANISM	1	MSEP	#6.5m x 3m HT.
DT-101	HYPOCHLORITE DOSING TANK	1	HDPE	100 LIT
DP-101 A/B	HYPOCHLORITE DOSING PUMPS	2	PP	0-5 LPH (ELECTRONIC TYPE)
DT-102	DEWATERING POLY DOSING TANK	1	HDPE	100 LIT
M-102	AGITATOR FOR DEWATERING POLY DOSING TANK	1	SS	SUITABLE
DP-102 A/B	DEWATERING POLY DOSING PUMPS	2	PP	0-20 LPH (ELECTRONIC TYPE)
P-104 A/B	FILTER PRESS FEED PUMPS	2	CI	3m ³ /hr @ 60 m head
FP-101	FILTER PRESS	1	SUITABLE	SUITABLE

ETP EQUIPMENT LIST

TAG No.	DESCRIPTION	QTY.	MOC	SIZE
M-103	FLASH MIXER AGITATOR	1	MSEP	SUITABLE
AGR-104	AERATION GRIDS FOR EQUALIZATION TANK	LOT	HDPE	SUITABLE
P-105 A/B	EFFLUENT TRANSFER PUMPS (SUBMERSIBLE TYPE)	2	CI	1.5m ³ /hr @ 10 m head
P-106 A/B	PRIMARY SLUDGE TRANSFER PUMPS	2	CI	1.0m ³ /hr @ 10-12 m head
DT-103	ALUM DOSING TANK	1	HDPE	100 LIT
TH-102	TUBE MEDIA FOR TUBE SETTLER	LOT	PP/PVC	SUITABLE FOR VOLUME OF TANK

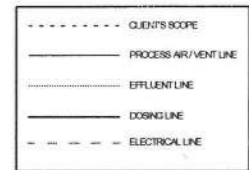

LEGEND		ABBREVIATIONS			
	BALL VALVE	P	PUMP	LS	LEVEL SWITCH
	DISC DIFFUSER	T	TANK	EFT	EFFLUENT
	HIGH RETURN VALVE	MS	MILD STEEL	TR	TREATED EFFLUENT
	BUTTERFLY VALVE	MSEP	MILD STEEL EPOXY PAINTED	AG	AGITATOR
	FLOW CONTROL VALVE	SW	SERVICE WATER	OG	OIL SKIMMER
	PRESSURE RELIEF VALVE	HDPE	HIGH DENSITY POLYETHYLENE	BSC	BAR SCREEN
	CENTRIFUGAL PUMP	PP	POLYPROPYLENE	CM	CLAMPING MECHANISM
	SCREW PUMP	CI	CAST IRON	OD	OUTER DIAMETER
	METERS PUMP	SS	STAINLESS STEEL	NW	NEW STUDY VALVE
	FLANGE CONNECTION	PG	PRESSURE GAUGE	WM	WATER METER
	PROGRAMMABLE LOGIC CONTROLLER	BL	BLOWER		
	ELECTRONIC DRIVE LEVEL SWITCH				
	PRESSURE GAUGE				

LEGEND FOR LINE NO.	
---	SERVICE - LINE SIZE - MOC - SEQUENCE NO.



AQUACHEM ENVIRO ENGINEERS PVT. LTD.
 5th & 6th FLOOR, SUNSHINE CLASSIC, OPP. ING. VYASIA BANK,
 HANUMAN ROAD, VILE PARLE (E), MUMBAI - 400 057.
 PHONE : (022) 2 611 9768/ 9752/ 2 610 1217/ 2 610 7723 FAX: (022) 2 610 3616

DRAWN	KIRAN	CHECKED	:- SEWAGE & EFFLUENT TREATMENT PLANT
CHECKED	ETG	CLIENT	:- M/A. MGR
APPROVED	MPN	LOCATION	:- MIRANGABAD
DATE	18.11.2014	CONSULTANTS	:- M/A. AQUACHEM ENVIRO ENGINEERS PVT. LTD.
SCALE	N/T	TITLE	:- P & I DIAGRAM FOR SEWAGE & EFFLUENT TREATMENT PLANT
		SHEET	1 OF 1

TEST CERTIFICATE

Report No: GESEC/PRO/2019-20/01/53	Date of Report	17/01/2020
Client Name and Address: M/s. MGM's Medical Collage & Hospital, N-6, CIDCO, Aurangabad, 432003.	Date of Sampling	10/01/2020
	Start Date of Analysis	11/01/2020
	End Date of Analysis	16/01/2020
	Sample Details	ETP Inlet
	Nature of sample	Liquid
Sample Collected By	Envirotech Research Pvt. Ltd.	

Water Analysis Report

Sr. No.	Parameter	Result	Unit(s)	Standard Method
Physical Parameter				
1.	TDS	819.6	ppm	APHA 2540-C
2.	Total Suspended Solid	45	mg/lit	APHA 2540-D
Chemical Parameter				
3.	pH	7.71	--	APHA 4500-H ⁺
4.	BOD at 27°C for 3 days	28	mg/lit	APHA 5210 B
5.	Oil and grease	1	mg/lit	APHA 5520 B
6.	COD	56	mg/lit	APHA 5220 B
7.	Detergent	0.01	mg/lit	Methylene blue extraction method
ANALYZED BY-		AUTHORIZED SIGNATORY		
				
				

Terms and conditions



- The report is refer only to the sample tested and not applies to the bulk.
- The results shown in this test report may differ based on various factors including temperature, humidity, pressure, retention time etc.
- The test report cannot be reproduced wholly or in part and cannot be used for promotional or publicity purpose without the written consent of laboratory, GESEC.
- Samples will be retained for a period of seven (7) days after completion of analysis. Longer retention periods can be arranged, on request of the customer.
- We strictly maintain the confidentiality of all test result of sample(s) collected by us/ supplied by customer and not revel to third party unless required by the statutory or legal requirement
- MoEF approved Lab by Govt. of India. From date 09/02/2017 to 08/02/2022.



TEST CERTIFICATE

Report No: GESEC/PRO/2019-20/01/52	Date of Report	17/01/2020
Client Name and Address: M/s. MGM's Medical Collage & Hospital, N-6, CIDCO, Aurangabad, 432003.	Date of Sampling	10/01/2020
	Start Date of Analysis	11/01/2020
	End Date of Analysis	16/01/2020
	Sample Details	STP Inlet
	Nature of sample	Liquid
Sample Collected By	Envirotech Research Pvt. Ltd.	

Water Analysis Report

Sr. No.	Parameter	Result	Unit(s)	Standard Method
Physical Parameter				
1.	Total Suspended Solid	59.2	mg/lit	APHA 2540-D
Chemical Parameter				
2.	BOD at 27°C for 3 days	140	mg/lit	APHA 5210 B
3.	COD	272	mg/lit	APHA 5220 B
4.	Residual chlorine	NA	ppm	Chlortext Method
ANALYZED BY-		AUTHORIZED SIGNATORY		
				
				

Terms and conditions

- The report is refer only to the sample tested and not applies to the bulk.
- The results shown in this test report may differ based on various factors including temperature, humidity, pressure, retention time etc.
- The test report cannot be reproduced wholly or in part and cannot be used for promotional or publicity purpose without the written consent of laboratory, GESEC.
- Samples will be retained for a period of seven (7) days after completion of analysis. Longer retention periods can be arranged, on request of the customer.
- We strictly maintain the confidentiality of all test result of sample(s) collected by us/ supplied by customer and not revel to third party unless required by the statutory or legal requirement
- MoEF approved Lab by Govt. of India. From date 09/02/2017 to 08/02/2022.



TEST CERTIFICATE

Report No: GESEC/PRO/2019-20/01/54	Date of Report	17/01/2020
Client Name and Address: M/s. MGM's Medical Collage & Hospital, N-6, CIDCO, Aurangabad, 432003.	Date of Sampling	10/01/2020
	Start Date of Analysis	11/01/2020
	End Date of Analysis	16/01/2020
	Sample Details	ETP OUTLET
	Nature of sample	Liquid
Sample Collected By	Envirotech Research Pvt. Ltd.	

Water Analysis Report

Sr. No.	Parameter	Result	MPCB Limits	Unit(s)	Standard Method
Physical Parameter					
1.	TDS	545.4	2100	ppm	APHA 2540-C
2.	Total Suspended Solid	12	100	mg/lit	APHA 2540-D
Chemical Parameter					
3.	pH	7.7	5.5-9.0	--	APHA 4500-H ⁺
4.	BOD at 27°C for 3 days	16	30	mg/lit	APHA 5210 B
5.	Oil and grease	BDL	<10	mg/lit	APHA 5520 B
6.	COD	38	<250	mg/lit	APHA 5220 B
7.	Detergent	BDL	2	mg/lit	Methylene blue extraction method

Remark(s):

➤ All parameters are within the MPCB limit.

ANALYZED BY-

[Signature]

AUTHORIZED SIGNATORY



[Signature]

Terms and conditions

- The report is refer only to the sample tested and not applies to the bulk.
- The results shown in this test report may differ based on various factors including temperature, humidity, pressure, retention time etc.
- The test report cannot be reproduced wholly or in part and cannot be used for promotional or publicity purpose without the written consent of laboratory, GESEC.
- Samples will be retained for a period of seven (7) days after completion of analysis. Longer retention periods can be arranged, on request of the customer.
- We strictly maintain the confidentiality of all test result of sample(s) collected by us/ supplied by customer and not revel to third party unless required by the statutory or legal requirement
- MoEF approved Lab by Govt. of India. From date 09/02/2017 to 08/02/2022.

TEST CERTIFICATE

Report No: GESEC/PRO/2019-20/01/55	Date of Report	17/01/2020
Client Name and Address: M/s. MGM's Medical Collage & Hospital, N-6, CIDCO, Aurangabad, 432003.	Date of Sampling	10/01/2020
	Start Date of Analysis	11/01/2020
	End Date of Analysis	16/01/2020
	Sample Details	STP OUTLET
	Nature of sample	Liquid
Sample Collected By	Envirotech Research Pvt. Ltd.	

Water Analysis Report

Sr. No.	Parameter	Result	MPCB Limits	Unit(s)	Standard Method
Physical Parameter					
1.	Total Suspended Solid	07	10	mg/lit	APHA 2540-D
Chemical Parameter					
2.	BOD at 27°C for 3 days	08	<10	mg/lit	APHA 5210 B
3.	COD	20	<50	mg/lit	APHA 5220 B
4.	Residual Chlorine	Absent	1	ppm	Chlortext Method

Remark(s): All parameters are within the MPCB limit.

ANALYZED BY-

[Handwritten Signature]



AUTHORIZED SIGNATORY

[Handwritten Signature]

Terms and conditions

- The report is refer only to the sample tested and not applies to the bulk.
- The results shown in this test report may differ based on various factors including temperature, humidity, pressure, retention time etc.
- The test report cannot be reproduced wholly or in part and cannot be used for promotional or publicity purpose without the written consent of laboratory, GESEC.
- Samples will be retained for a period of seven (7) days after completion of analysis. Longer retention periods can be arranged, on request of the customer.
- We strictly maintain the confidentiality of all test result of sample(s) collected by us/ supplied by customer and not revel to third party unless required by the statutory or legal requirement
- MoEF approved Lab by Govt. of India. From date 09/02/2017 to 08/02/2022.

Water Treatment Plant with potability certificate



MGM INSTITUTE OF HEALTH SCIENCES

Accredited by NAAC with 'A' Grade

(Deemed University u/s 3 of UGC Act, 1956)

Sector-01, Kamothe, Navi Mumbai - 410 209

Tel 022-27432471, 022-27432994, Fax 022 - 27431094

E-mail : registrar@mgmuhs.com ; Website : www.mgmuhs.com

SALIENT FEATURES OF THE WATER TREATMENT PLANT (WTP) AT MGMIHS Navi Mumbai Campus

A Water Treatment Plant has been established at the Navi Mumbai Campus to treat rain water into potable water and to treat grey water (domestically used water) into potable water during non-monsoon period. The processing capacity is 80 Kilolitres / day on an average. The plant is operational since January 2019 and is delivering potable quality water as indicated in laboratory tests done and reports of government laboratory (PHL).

The WTP installed is unique in many respects and first of its kind in India:

- a) Vertically structured plant in which unprocessed water flows mostly by gravity and a pump of only 1.5 HP is used to lift the water within the processing plant. This is a source of enormous saving of life cycle energy cost.
- b) The plant has been designed to operate automatically requiring no human intervention in processing thereby standardizing processing parameters and saving manpower costs. Operator task is limited to filling dosing vessels with processing chemicals.
- c) The plant does not use Chlorine to disinfect. It uses AOP (Advanced Oxidizing Process), a combination of very high intensity UV radiation with chemical dosing to magnify UV potential in disinfection process.
- d) For residual disinfection, the plant uses CLO₂ instead of chlorine which does not generate harmful By-products like THM and HAA.
- e) The plant is designed to economize space and occupies only 7.5 metres x 11 metres plinth area being vertically extended structure to treat huge volume of 80,000 litres/day.
- f) Processing cost is between Rs. 0.03 to Rs. 0.035 per litre to convert grey water into potable quality.

The second plant is now being installed to treat 100 Kilolitres per day at the same site.

The plant has several proprietary components designed and developed by Prof. R. N. Dutt, Technical Consultant at MGMIHS, a former Professor and Dean at Uttarakhand Technical University and also a former UNDP /WB consultant.

Registrar

Dr. Rajesh B. Goel

Registrar

MGM Institute of Health Sciences
(Deemed University u/s 3 of UGC Act, 1956)
Navi Mumbai- 410 209

Public Health Laboratory, Government of Maharashtra

महाराष्ट्र राज्य सार्वजनिक आरोग्य सेवा

राज्य / प्रादेशिक / जिल्हा आरोग्य प्रयोगशाळा, कोकणभवन दूरध्वनी क्रमांक

पाणी नमुन्याचा सूक्ष्मजीवीय अहवाल

प्रति, ✓ :- Deam, M.G.M Medical College & Hospital
Karnathe, Navi Mumbai

पाठविणाऱ्यांचे पत्र क्रमांक व दिनांक :- 102-11-19.

प्रयोगशाळा संदर्भ क्रमांक :- 8630

नमुना घेतल्याचा दिनांक :- 05-11-19

नमुना पोहचल्याचा दिनांक :- ———

परीक्षण सुरु केल्याचा दिनांक :- ———

अ. क्र.	नमुन्याचे विवरण	परीक्षणाचे निष्कर्ष			इतर अभिप्राय
		प्रती १०० मि.ली. नमुन्यातील संभाव्य सूक्ष्मजंतूची संख्या			
		कोलीफॉर्मस	थर्मोटॉलरंट कोलीफॉर्मस	इ. कोलाय	
1)	Water sample from Water treatment plant	0	—	—	potable.

अभिप्राय : पिण्यास अयोग्य पाण्यावर योग्य प्रमाणात क्लोरिनची प्रक्रिया केल्यानंतर व सूक्ष्मजीवीय पुनर्तपासणीनंतर पिण्यास योग्य असल्याची खात्री झाल्यानंतरच ते पाणी पिण्यासाठी वापरता येईल.

अहवाल क्रमांक : 2780

दिनांक :-

08 NOV 2019

अभिप्राय तारेने कळविल्याचा दिनांक :

प्रत सादर :

- (१) जिल्हा आरोग्य अधिकारी / जिल्हा परिषद, जिल्हा
- (२) शल्यचिकित्सक, जिल्हा रुग्णालय, जिल्हा
- (३) गटविकास अधिकारी, पंचायत समिती

[Signature]
कनिष्ठ सार्वजनिक आरोग्य अधिकारी
सार्वजनिक आरोग्य प्रयोगशाळा
कोकण भवन



MUNICIPAL CORPORATION OF GREATER MUMBAI

Public Health Department

**It is distinctly understood that
this report will not be used for
advertisement purposes**

**MUNICIPAL LABORATORY
Centralised G/North Offices, 2nd Floor,
Room No. 49, J. K. Sawant Marg,
Dadar, Mumbai-400 028.**

ANALYSIS REPORT

Customer Name & Address	REPORT NO.	PB/1162 of 2019
Mahatma Gandhi Mission's Medical college Sector 1, Kamothe Navi Mumbai 410209	Sample Id.	MA/19/4527
	Date of Receipt	05.11.2019
	Quantity	250 ml
Sample Description : Drinking Water		
Analysis Started on :- 05.11.2019		Analysis Completed on :- 06.11.2019

SR. NO.	TEST	RESULTS	ACCEPTABLE LIMITS	METHOD USED
1.	Coliform Bacteria 1 x 100ml	Absent	Shall not be detectable in any 100 ml sample	IS 1622:1981
2.	E.coli Bacteria 1 x 100ml	Absent	Shall not be detectable in any 100 ml sample	IS 1622:1981

OPINION : As per referred to the above tests, the sample of Drinking Water conforms to the standards prescribed in IS:10500 of 2012 & hence bacteriologically safe for drinking purpose.

AUTHORISED SIGNATORY

SHRI. M. V. HALDANKAR
Assistant Analyst



BMPP-21801-2015-16-50,000

PH401

MUNICIPAL CORPORATION OF GREATER MUMBAI

Public Health Department

**It is distinctly understood that
this report will not be used for
advertisement purposes**

**MUNICIPAL LABORATORY
Centralised G/North Offices, 2nd Floor,
Room No. 49, J. K. Sawant Marg,
Dadar, Mumbai-400 028.**

ANALYSIS REPORT

Customer Name & Address	REPORT NO.	PC/4656 of 2019
Mahatma Gandhi Mission's Medical college Sector 1, Kamothe Navi Mumbai 410209	Sample Id.	MA/19/4526
	Date of Receipt	05.11.2019
	Quantity	1 lit
Sample Description :- Drinking water		
Analysis Started on :- 06.11.2019		Analysis Completed on :- 08.11.2019

SR. NO.	TEST	RESULTS	ACCEPTABLE LIMITS	METHOD USED
1.	Physical Appearance	Clear	Clear	By visual examination
2.	Odour	Aggreable	Agreeable	IS 3025 Part 05:1983 Reaffirmed 1996
3.	Turbidity	0.97 NTU	Not more than 1.0 NTU	IS 3025 Part 10:1984 Reaffirmed 1996
4.	Dissolved Solids	405.0 mg/lit.	Not more than 500.00 mg/lit.	By TDS Electrode
5.	pH	6.98	6.5 to 8.5	IS 3025 Part 11:1983 Reaffirmed 1996
6.	Total Hardness (As CaCO ₃)	172.2 mg/lit.	Not more than 200.0 mg/lit.	IS 3025 Part 21:1983 Reaffirmed 2009
7.	Chloride (As Cl)	133.65 mg/lit.	Not more than 250.0 mg/lit.	IS 3025 Part 32:1988 Reaffirmed 1999
8.	Total Alkalinity (As CaCO ₃)	180.4 mg/lit.	Not more than 200.0 mg/lit.	IS 3025 Part 23:1986 Reaffirmed 1998
9.	Nitrate (As NO ₃)	20.0 mg/lit	Not more than 45.0 mg/lit.	By Nitrate Test Kit

OPINION: As per referred to the above tests, the given sample of drinking water conforms to the standards prescribed in IS:10500 of 2012 & hence chemically fit for drinking purpose.

AUTHORISED SIGNATORY

SHRI. M. V. HALDANKAR
Assistant Analyst